

AIR CONDITIONER

**2-unit multi-split type,
3-unit multi-split type,
4-unit multi-split type,
5-unit multi-split type**

SERVICE MANUAL

INDOOR



WHP07WMA21S
WHP09WMA21S
WHP12WMA21S



WHP18WMA21S
WHP24WMA21S



WHU09CTA21S
WHU12CTA21S



WHU18CTA21S
WHU24CTA21S



WHU09DHA21S
WHU12DHA21S



WHU18DHA21S



WHU24DHA21S

OUTDOOR



WHP18M2A21S



WHP24M3A21S



WHP36M4A21S
WHP42M5A21S

Notices:

- Product specifications and design are subject to change without notice for future improvement.
- For further details, please check with our authorized dealer.

SAFETY SUMMARY

IMPORTANT NOTICE

- We pursue a policy of continuing improvement in design and performance of products. The right is therefore reserved to vary specifications without notice.
- We cannot anticipate every possible circumstance that might involve a potential hazard.
- This air conditioner is designed for standard air conditioning only. Do not use this air conditioner for other purposes such as drying clothes, refrigerating foods or for any other cooling or heating process. Do not let the air-out face animals or plants, it might have an adverse effect on them.
- The installer and system specialist shall secure safety against leakage according to local regulations or standards.
- Signal words (DANGER, WARNING and CAUTION) are used to identify levels of hazard seriousness. Definitions for identifying hazard levels are provided below with their respective signal words.

▲ DANGER

: Immediate hazards which WILL result in severe personal injury or death.

▲ WARNING

: Hazards or unsafe practices which COULD result in severe personal injury or death.

▲ CAUTION

: Hazards or unsafe practices which COULD result in minor personal injury or product or property damage.

NOTE

: Useful information for operation and/or maintenance.

- Installation should be performed by the dealer or other professional personnel. Improper installation may cause water leakage, electrical shock, or fire.

▲ DANGER

- Do not perform installation work, refrigerant piping work, drain piping and electrical wiring connection without referring to our installation manual. If the instructions are not followed, it may result in water leakage, electric shock or fire.
- Use refrigerant R410A in the refrigerant cycle.
- Do not pour water into the indoor or outdoor unit. These products are equipped with electrical parts. If poured, it will cause a serious electrical shock.
- Do not open the service cover or access panel for the indoor or outdoor units without turning OFF the main power supply.
- Do not touch or adjust safety devices inside the indoor or outdoor units. If these devices are touched or readjusted, it may cause a serious accident.
- Refrigerant leakage can cause difficulty in breathing due to insufficient air. Turn OFF the main switch, extinguish any naked flames and contact your service contractor, if refrigerant leakage occurs.
- Do perform air-tight test. Do not charge oxygen, acetylene or other flammable and poisonous gases into the refrigerant cycle when performing a leakage test or an air-tight test. These types of gases are extremely dangerous and can cause an explosion. It is recommended that nitrogen be used for this test.
- The installer and system specialist shall secure safety against refrigerant leakage according to local regulations or standards.
- Use an ELB (Electric Leakage Breaker). In the event of a fault, there is danger of an electric shock or a fire if it is not used.

⚠ WARNING

- Do not use any sprays such as insecticide, lacquer, hair spray or other flammable gases within approximately one (1) meter from the system.
- If circuit breaker or fuse is often activated, stop the system and contact your service contractor.
- Check that the ground wire is securely connected. If the unit is not correctly grounded, it will lead to electric shock. Do not connect the ground wiring to gas piping, water piping, lightning conductor or ground wiring for telephone.
- Before performing any brazing work, check to ensure that there is no flammable material around when using refrigerant. Be sure to wear leather gloves to prevent cold injuries.
- Protect the wires, electrical parts, etc. from rats or other small animals.
If not protected, rats may gnaw at unprotected parts, which may lead to fire.
- Fix the cables securely. External forces on the terminals could lead to a fire.
- Install the air conditioner on a solid base that can support the unit weight. An inadequate base or incomplete installation may cause injury in the event the unit falls off the base. Incomplete connections or clamping may cause terminal overheating or fire.
- Make sure that the outdoor unit is not covered with snow or ice, before operation.

⚠ CAUTION

- Do not step or put any material on the product.
- Do not put any foreign material on the unit or inside the unit.

NOTE

- It is recommended that the room be ventilated every 3 to 4 hours.
- The air conditioner may not work properly under the following circumstances.
The power transformer provides the same power with the air conditioner. The electrical equipment is too close to the power supply of the air conditioner. With the sharp change of power consumption and switching action, the power supply of the air conditioner will generate a large induction surge voltage.

CHECKING PRODUCT RECEIVED

- Upon receiving this product, inspect it for any shipping damage. Claims for damage, either apparent or concealed, should be filed immediately with the shipping company.
- Check the model number, electrical characteristics (power supply, voltage and frequency) and accessories to determine if they are correct.

The standard utilization of the unit shall be explained in these instructions.

Therefore, the utilization of the unit other than those indicated in these instructions is not recommended.

Please contact your local agent, as the occasion arises.

Specifications

Wall mounted type

Type				Wall mounted				
				Inverter heat pump				
Model name				WHP07WMA21S	WHP09WMA21S	WHP12WMA21S		
Power supply				208/230 V ~ 60 Hz				
Power supply intake				Outdoor unit				
Available voltage range				198—253 V				
Capacity	Cooling	Rated	kW	2.052	2.64	3.51		
			Btu/h	7,000	9,000	12,000		
		Min.—Max.	kW	1.06—2.93	1.06—2.93	1.17—3.96		
	Heating	Rated	Btu/h	3,600—10,000	3,600—10,000	4,000—13,500		
			kW	2.491	2.78	3.81		
		Min.—Max.	Btu/h	8,500	9,500	13,000		
Input power	Cooling	Rated	kW	0.655	0.655	0.920		
				Min.—Max.	0.230—1.495	0.230—1.495	0.276—1.610	
		Heating		Rated	0.720	0.720	1.110	
	Min.—Max.				0.230—1.495	0.230—1.495	0.276—1.610	
	Current			Cooling	Rated	A	2.9	2.9
		Heating		Rated	A	2.9	2.9	5.0
Power factor	Cooling		%	98	98	96		
	Heating		%	98	98	97		
Moisture removal			pints/h (L/h)	1.9 (0.9)	1.9 (0.9)	2.5 (1.2)		
Fan	Airflow rate	Cooling	HIGHER	383 (650)	383 (650)	394 (670)		
			HIGH	341 (580)	341 (580)	365 (620)		
			MED	294 (500)	294 (500)	312 (530)		
			LOW	247 (420)	247 (420)	253 (430)		
			LOWER		224 (380)			
		Heating	HIGHER	383 (650)	383 (650)	394 (670)		
			HIGH	341 (580)	341 (580)	365 (620)		
			MED	294 (500)	294 (500)	312 (530)		
			LOW	247 (420)	247 (420)	253 (430)		
			LOWER		224 (380)			
	Type × Q'ty			Crossflow fan × 1				
	Motor output			W	25			
	Sound pressure level*2	Cooling	HIGHER	dB (A)	42			
			HIGH		39			
MED			32					
LOW			29					
LOWER			26					
Heating		HIGHER	42					
		HIGH	39					
		MED	32					
		LOW	29					
		LOWER	26					
Heat exchanger type	Dimensions (H × W × D)		in (mm)	11-9/16 × 24-7/16 × 1-1/16 (294 × 620 × 27.2)				
	Fin pitch		FPI	18				
	Rows × Stages			2 × 14				
	Pipe type			Copper				
	Fin type			Aluminum				
Enclosure	Material			Polystyrene				
	Color			White				
Dimensions (H × W × D)	Net	in (mm)	10-5/8 × 33-7/16 × 8-7/16 (270 × 850 × 215)					
	Gross		13-3/16 × 37 × 10-7/16 (335 × 940 × 265)					
Weight	Net	lb (kg)	20 (9)					
	Gross		24 (11)	24 (11)	26 (12)			
Connection pipe	Size	Liquid	in (mm)	Ø1/4 (Ø6.35)				
		Gas		Ø3/8 (Ø9.52)				
	Method	Flare						
Drain hose	Material		PE/PVC					
	Tip diameter		in (mm)	Ø5/8 (Ø15.4) (I.D.), Ø7/8 (Ø23) (O.D.)				
Operation range	Cooling	°F (°C)		61 to 86 (16 to 30)				
		%RH		80 or less				
Remote controller type	Heating	°F (°C)		61 to 86 (16 to 30)				
		Wireless (Wired [option])						

NOTES:

- Specifications are based on the following conditions:
 - Cooling: Indoor temperature of 80 °FDB (26.67 °CDB) / 67 °FWB (19.44 °CWB), and outdoor temperature of 95 °FDB (35 °CDB) / 75 °FWB (23.9 °CWB).
 - Heating: Indoor temperature of 70 °FDB (21.11 °CDB) / 59 °FWB (15.56 °CWB), and outdoor temperature of 47 °FDB (8.33 °CDB) / 43 °FWB (6.11 °CWB).
 - Pipe length: 25 ft (7.5 m), Height difference: 0 ft (0 m). (Between outdoor unit and indoor unit.)
- Protective function might work when using it outside the operation range.
- *1: Maximum current is maximum value when operated within the operation range.
- *2: Sound pressure level:
 - Measured values in manufacturer's anechoic chamber.
 - Because of the surrounding sound environment, the sound levels measured in actual installation conditions might be higher than the specified values here.

Type				Wall mounted			
				Inverter heat pump			
Model name				WHP18WMA21S	WHP24WMA21S		
Power supply				208/230 V ~ 60 Hz			
Power supply intake				Outdoor unit			
Available voltage range				198—253 V			
Capacity	Cooling	Rated	kW	5.28	6.86		
			Btu/h	18,000	23,400		
		Min.—Max.	kW	1.905—5.7153	2.345—7.767		
	Heating	Rated	Btu/h	6,500—19,500	8,000—26,500		
			kW	5.57	7.62		
		Min.—Max.	Btu/h	19,000	26,000		
Input power	Cooling	Rated	kW	1.385	1.870		
			Min.—Max.	0.345—2.760	0.414—2.990		
		Heating	Rated	1.638	2.500		
	Current	Cooling	Rated	A	6.3	8.3	
				Heating	7.2	11.1	
		Power factor	Cooling		%	96	98
Moisture removal	Heating			99	98		
			pints/h (L/h)	3.2 (1.5)	5.1 (2.4)		
Fan	Airflow rate	Cooling	HIGHER	647 (1,100)	706 (1,200)		
			HIGH	589 (1,000)	647 (1,100)		
			MED	483 (820)	559 (950)		
			LOW	459 (780)	441 (750)		
			LOWER	383 (650)	368 (625)		
			CFM (m ³ /h)	647 (1,100)	706 (1,200)		
		Heating	HIGHER	589 (1,000)	647 (1,100)		
			HIGH	483 (820)	559 (950)		
			MED	459 (780)	441 (750)		
			LOW	383 (650)	368 (625)		
			Type × Q'ty	Crossflow fan × 1			
			Motor output	W			
Sound pressure level ³	Cooling	HIGHER	48	50			
		HIGH	45	47			
		MED	41	42			
		LOW	37	36			
		LOWER	34	33			
		dB (A)	48	50			
	Heating	HIGHER	45	47			
		HIGH	41	42			
		MED	37	36			
		LOW	34	33			
		Heat exchanger type	Dimensions (H × W × D)	in (mm)	14-7/8 × 33-1/8 × 1-1/16 (378 × 842 × 27.2)		
		Fin pitch	FPI	18			
Rows × Stages	2 × 18						
Pipe type	Copper						
Fin type	Aluminum						
Enclosure	Material	Polystyrene					
	Color	White					
Dimensions (H × W × D)	Net	in (mm)	12-3/8 × 44-1/2 × 9-5/16 (315 × 1,130 × 237)				
	Gross		15-3/8 × 47-5/8 × 12-7/16 (390 × 1,210 × 316)				
Weight	Net	lb (kg)	32 (14.5)				
	Gross		37 (17)				
Connection pipe	Size	Liquid	in (mm)	Ø1/4 (Ø6.35)	Ø3/8 (Ø9.52)		
		Gas		Ø1/2 (Ø12.70)	Ø5/8 (Ø15.88)		
	Method	Flare					
Drain hose	Material	PE/PVC					
	Tip diameter	in (mm)	Ø5/8 (Ø15.4) (I.D.), Ø7/8 (Ø23) (O.D.)				
Operation range	Cooling	°F (°C)	61 to 86 (16 to 30)				
	Heating	%RH	80 or less				
Remote controller type	Heating		°F (°C)	61 to 86 (16 to 30)			
				Wireless (Wired [option])			
NOTES:							
<ul style="list-style-type: none"> Specifications are based on the following conditions: <ul style="list-style-type: none"> Cooling: Indoor temperature of 80 °FDB (26.67 °CDB) /67 °FWB (19.44 °CWB), and outdoor temperature of 95 °FDB (35 °CDB) / 75 °FWB (23.9 °CWB). Heating: Indoor temperature of 70 °FDB (21.11 °CDB) /59 °FWB (15.56 °CWB), and outdoor temperature of 47 °FDB (8.33 °CDB) /43 °FWB (6.11 °CWB). Pipe length: 25 ft (7.5 m), Height difference: 0 ft (0 m). (Between outdoor unit and indoor unit.) Protective function might work when using it outside the operation range. *1: Maximum current is maximum value when operated within the operation range. *2: Sound pressure level: <ul style="list-style-type: none"> Measured values in manufacturer's anechoic chamber. Because of the surrounding sound environment, the sound levels measured in actual installation conditions might be higher than the specified values here. 							

Cassette type

Type				Cassette					
				Inverter heat pump					
Model name				WHU09CTA21S	WHU12CTA21S	WHU18CTA21S	WHU24CTA21S		
Power supply				208/230 V ~ 60 Hz					
Power supply intake				Outdoor unit					
Available voltage range				198—253 V		176—253 V			
Capacity	Cooling	Rated	kW	2.64	3.52	5.28	7.03		
			Btu/h	9,000	12,000	18,000	24,000		
		Min.—Max.	kW	1.27—3.40	1.70—3.84	1.23—6.16	2.52—7.39		
	Heating	Rated	Btu/h	4,850—11,600	5,800—13,100	4,200—21,000	8,600—25,200		
			kW	2.93	3.52	5.57	7.03		
		Min.—Max.	kW	1.27—3.60	1.29—4.22	1.64—7.03	2.23—8.32		
Input power	Cooling	Rated	kW	0.700	0.960	1.420	1.920		
			Min.—Max.	kW	0.332—0.941	0.388—1.319	0.252—1.870	0.760—2.260	
		Heating	Rated	kW	0.709	0.926	1.425	1.950	
	Min.—Max.			kW	0.221—1.022	0.457—1.611	0.345—2.068	0.780—2.400	
	Current		Cooling	Rated	A	3.6	4.3	6.5	8.6
		Heating			A	3.5	4.1	6.3	8.7
Power factor				Cooling: 99 Heating: 99					
Moisture removal				pints/h (L/h)	1.7 (0.8)	2.3 (1.1)	3.2 (1.5)	4.0 (1.9)	
Fan	Airflow rate	Cooling	HIGH	CFM (m ³ /h)	309 (520)	324 (550)	588 (1,000)	647 (1,100)	
			MED		274 (460)	294 (500)	500 (850)	530 (900)	
			LOW		232 (390)	235 (400)	394 (670)	400 (680)	
		Heating	HIGH		309 (520)	324 (550)	588 (1,000)	647 (1,100)	
			MED		274 (460)	294 (500)	500 (850)	530 (900)	
			LOW		232 (390)	235 (400)	394 (670)	400 (680)	
	Type × Q'ty				Turbo × 1				
	Motor output				W	57		80	
	Sound pressure level*2	Cooling	HIGH	dB (A)	38	42	38	44	
					MED	34	37	36	40
LOW					31	33	34	38	
Heating		HIGH	38		42	38	44		
			MED		34	37	36	40	
			LOW		31	33	34	38	
Heat exchanger type	Dimensions (H × W × D)		in (mm)	6-9/16 × 49-1/2 × 3/4 (166 × 1,258 × 18.8)	6-9/16 × 47-3/4 × 1-1/8 (166.7 × 1,213 × 28.2)	7-7/16 × 73-5/8 × 1-1/16 (189 × 1,870 × 27.2)	7-7/16 × 76-3/8 × 1-5/8 (189 × 1,940 × 40.8)		
	Fin pitch		FPI	20		17			
	Rows × Stages			2 × 8	3 × 8	2 × 10	3 × 10		
	Pipe type			Copper					
	Fin type			Aluminum					
Dimensions (H × W × D)	Net		in (mm)	8-1/2 × 22-1/2 × 22-1/2 (215 × 570 × 570)		9-3/4 × 33-1/8 × 33-1/8 (248 × 840 × 840)			
	Gross			4-1/2 × 26-3/4 × 27-1/8 (292 × 668 × 730)		4-3/4 × 40 × 40-3/8 (370 × 956 × 996)			
Weight	Net		lb (kg)	32 (14.5)	34 (15.5)	56 (25)	59.5 (27)		
	Gross			38.5 (17.5)	40.5 (18.5)	76 (34)	79.5 (36)		
Connection pipe	Size	Liquid	in (mm)	Ø1/4 (Ø6.35)		Ø1/4 (Ø6.35)	Ø3/8 (Ø9.52)		
		Gas		Ø3/8 (Ø9.52)		Ø1/2 (Ø12.70)	Ø5/8 (Ø15.88)		
Method				Flare					
Material				PE/PVC					
Drain hose		Tip diameter		in (mm)				Ø1-1/8 (Ø27.8) (I.D.), Ø1-1/4 (Ø32.3) (O.D.)	
Operation range	Cooling	°F (°C)		61 to 86 (16 to 30)					
		%RH		80 or less					
Heating		°F (°C)		61 to 86 (16 to 30)					
Remote controller type				Wireless (Wired [option])					
Cassette grille (Grid type: Option)	Model name			WH-AG4CT1		WH-AG4CT2			
	Dimensions (H × W × D)	Net	in (mm)	1-5/8 × 24-3/8 × 24-3/8 (40 × 620 × 620)		1-3/4 × 37-3/8 × 37-3/8 (45 × 950 × 950)			
		Gross		4-1/2 × 26-3/4 × 27-1/8 (115 × 680 × 690)		4-3/4 × 40 × 40-3/8 (120 × 1,015 × 1,025)			
	Weight	Net	lb (kg)	5.7 (2.6)		14.3 (6.5)			
		Gross		9.9 (4.5)		20.9 (9.5)			
NOTES:									
<ul style="list-style-type: none"> Specifications are based on the following conditions: <ul style="list-style-type: none"> Cooling: Indoor temperature of 80 °FDB (26.67 °CDB)/67 °FWB (19.44 °CWB), and outdoor temperature of 95 °FDB (35 °CDB)/75 °FWB (23.9 °CWB). Heating: Indoor temperature of 70 °FDB (21.11 °CDB)/59 °FWB (15.56 °CWB), and outdoor temperature of 47 °FDB (8.33 °CDB)/43 °FWB (6.11 °CWB). Pipe length: 25 ft (7.5 m), Height difference: 0 ft (0 m). (Between outdoor unit and indoor unit.) Protective function might work when using it outside the operation range. *1: Maximum current is maximum value when operated within the operation range. *2: Sound pressure level: <ul style="list-style-type: none"> Measured values in manufacturer's anechoic chamber. Because of the surrounding sound environment, the sound levels measured in actual installation conditions might be higher than the specified values here. 									

Duct type

Type				Duct				
				Inverter heat pump				
Model name				WHU09DHA21S	WHU12DHA21S	WHU18DHA21S	WHU24DHA21S	
Power supply				208/230 V ~ 60 Hz				
Power supply intake				Outdoor unit				
Available voltage range				198—253 V		176—253 V		
Capacity	Cooling	Rated	kW	2.64	3.52	5.28	7.03	
			Btu/h	9,000	12,000	18,000	24,000	
		Min.—Max.	kW	1.42—3.40	1.70—3.84	1.23—6.16	2.49—7.91	
	Heating	Rated	kW	4,850—11,600	5,800—13,100	4,200—21,000	8,500—27,000	
			Btu/h	3.22	3.52	5.28	8.21	
		Min.—Max.	kW	1.27—3.60	1.29—4.22	1.64—7.03	2.23—8.32	
Input power	Cooling	Rated	kW	0.750	1.091	1.670	2.290	
			Min.—Max.	kW	0.390—0.994	0.375—1.280	0.278—1.980	0.730—2.170
		Heating	Rated	kW	0.908	1.091	1.600	2.275
	Heating	Rated	kW	0.229—1.043	0.457—1.611	0.381—2.320	0.749—2.304	
			Min.—Max.	kW	0.750	1.091	1.670	2.290
		Heating	Rated	kW	0.390—0.994	0.375—1.280	0.278—1.980	0.730—2.170
Current	Cooling	Rated	A	3.7	4.8	7.6	10.3	
	Heating		A	3.9	4.8	7.3	8.7	
Power factor		Cooling	99					
		Heating	99					
Moisture removal			pints/h (L/h)	1.7 (0.8)	2.3 (1.1)	3.2 (1.5)	4.0 (1.9)	
Fan	Airflow rate	Cooling	HIGH	309 (520)	324 (550)	529 (900)	706 (1,200)	
			MED	259 (435)	285 (484)	441 (750)	588 (1,000)	
			LOW	208 (350)	235 (400)	371 (630)	500 (850)	
		Heating	HIGH	309 (520)	324 (550)	529 (900)	706 (1,200)	
			MED	259 (435)	285 (484)	441 (750)	588 (1,000)	
			LOW	208 (350)	235 (400)	371 (630)	500 (850)	
	Type × Q'ty		Sirocco × 2		Sirocco × 3		Sirocco × 2	
	Motor output		W		40		60	
	Static pressure range			inWG (Pa)	0 to 0.2 (0 to 50)		0.1 to 0.4 (25 to 100)	
	Sound pressure level*2	Cooling	HIGH	35	36	38	42	
MED			33	34	37	38		
LOW			32	33	36	36		
Heating		HIGH	35	36	38	42		
		MED	33	34	37	38		
		LOW	32	33	36	36		
Heat exchanger type	Dimensions (H × W × D)		in (mm)	8-1/4 × 28-13/16 × 1-5/8 (210 × 732 × 40.8)	8-1/4 × 39-7/16 × 1-5/8 (210 × 1,002 × 40.8)	11-9/16 × 27-9/16 × 1-5/8 (294 × 700 × 40.8)		
	Fin pitch		FPI	16				
	Rows × Stages			3 × 10		3 × 14		
	Pipe type			Copper				
	Fin type			Aluminum				
Dimensions (H × W × D)	Net		in (mm)	7-1/2 × 35-7/8 × 17-5/8 (190 × 910 × 447)	7-1/2 × 46-1/2 × 17-5/8 (190 × 1,180 × 447)	10-5/8 × 35-3/8 × 28-3/8 (270 × 900 × 720)		
	Gross		in (mm)	11-1/4 × 42-1/2 × 22-1/4 (285 × 1,080 × 565)	11-1/4 × 53-1/8 × 22-1/4 (285 × 1,350 × 565)	13-3/8 × 46-1/8 × 34-1/4 (340 × 1,170 × 870)		
Weight	Net		lb (kg)	39.7 (18)	49.6 (22.5)	66.1 (30)		
	Gross		lb (kg)	46.3 (21)	57.3 (26)	77.2 (35)		
Connection pipe	Size	Liquid	in (mm)	Ø1/4 (Ø6.35)	Ø1/4 (Ø6.35)	Ø1/4 (Ø6.35)		
		Gas	in (mm)	Ø3/8 (Ø9.52)	Ø1/2 (Ø12.70)	Ø5/8 (Ø15.88)		
	Method			Flare				
Drain hose	Material			PVC				
	Tip diameter		in (mm)	Ø1-1/8 (Ø27.8) (I.D.), Ø1-1/4 (Ø32.3) (O.D.)				
Operation range	Cooling		°F (°C)	61 to 86 (16 to 30)				
	Heating		%RH	80 or less				
			°F (°C)	61 to 86 (16 to 30)				
Remote controller type				Wired (IR receiver unit [option])				
IR receiver unit (Option)		Model name		WH-AIRDH1				
NOTES:								
<ul style="list-style-type: none"> Specifications are based on the following conditions: <ul style="list-style-type: none"> Cooling: Indoor temperature of 80 °FDB (26.67 °CDB)/67 °FWB (19.44 °CWB), and outdoor temperature of 95 °FDB (35 °CDB)/75 °FWB (23.9 °CWB). Heating: Indoor temperature of 70 °FDB (21.11 °CDB)/59 °FWB (15.56 °CWB), and outdoor temperature of 47 °FDB (8.33 °CDB)/43 °FWB (6.11 °CWB). Pipe length: 25 ft (7.5 m), Height difference: 0 ft (0 m). (Between outdoor unit and indoor unit.) Protective function might work when using it outside the operation range. *1: Maximum current is maximum value when operated within the operation range. *2: Sound pressure level: <ul style="list-style-type: none"> Measured values in manufacturer's anechoic chamber. Because of the surrounding sound environment, the sound levels measured in actual installation conditions might be higher than the specified values here. 								

Outdoor unit

Type			Inverter heat pump			
Model name			WHP18M2A21S	WHP24M3A21S		
Power supply			208/230 V ~ 60 Hz			
Available voltage range			198—253 V			
Connectable indoor unit	Number		2	2 to 3		
	Total capacity range		16,000 to 21,000 Btu/h	21,000 to 31,000 Btu/h		
Standard combination of indoor unit			WHP09WMA21S × 2	WHP12WMA21S × 2		
Capacity	Cooling	Rated	Btu/h	18,000	24,000	
			kW	5.275	7.034	
		Min.—Max.	Btu/h	7,500—24,000	8,000—30,200	
	Heating	Rated	Btu/h	18,000	24,000	
			kW	5.275	7.034	
		Min.—Max.	Btu/h	5,800—28,700	5,200—37,000	
Input power	Cooling	Rated	kW	1.44	1.92	
			Min.—Max.	0.51—2.61	0.42—2.64	
		Heating	Rated	1.53	1.92	
	Current	Cooling	Rated	A	6.5	8.7
				Heating	Rated	6.9
		EER	Cooling	W/W		3.66
Btu/hW				12.50		
COP	Heating	W/W	3.45	3.66		
		Btu/hW	11.76	12.50		
SEER	Cooling	Btu/hW		22.0		
HSPF	Heating	Btu/hW		11.0		
Fan	Airflow rate	CFM (m ³ /h)	1,854 (3,150)	2,354 (4,000)		
	Type × Q'ty		Propeller fan × 1			
	Motor output	W	73	121		
Sound pressure level *1			dB (A)	55	59	
Heat exchanger type	Dimensions (H × W × D)	in (mm)	35-7/16 × 24-13/16 × 11/16 (900 × 630 × 18.19)	38-3/16 × 31-7/16 × 11/16 (970 × 798 × 18.19)		
			35-7/16 × 24-13/16 × 11/16 (900 × 630 × 18.19)	38-3/16 × 31-7/16 × 11/16 (970 × 798 × 18.19)		
			Fin pitch	FPI	18	
	Rows × Stages		2 × 30	2 × 38		
	Pipe type		Copper			
	Fin type	Type (Material)	Aluminum			
	Surface treatment	Blue fin				
Compressor	Type		Rotary			
Refrigerant	Type		R410A			
	Charge	lb oz	3 lb 15 oz	5 lb 1 oz		
Refrigerant oil	Type		VG74 (POE)			
		Material		Steel sheet		
Enclosure	Color		White			
Dimensions (H × W × D)	Net	in (mm)	26-3/8 × 33-7/8 × 12-3/16 (670 × 860 × 310)	33-1/16 × 37-3/8 × 13-3/8 (840 × 950 × 340)		
	Gross		28-3/4 × 39 × 17-11/16 (730 × 990 × 450)	36-1/4 × 43-11/16 × 18-1/8 (920 × 1,110 × 460)		
Weight	Net	lb (kg)	117 (53)	159 (72)		
	Gross		126 (57)	170 (77)		
Connection pipe	Size	Liquid	Ø1/4 (Ø6.35)			
		Gas	Ø3/8 (Ø9.52)			
	Method		Flare			
	Pre-charge length	Total	ft (m)	49 (15)	73 (22.5)	
		Total		164 (50)	196 (60)	
	Max. length	Each	82 (25)	65 (20)		
Max. height difference			Indoor unit higher than outdoor unit: 49 (15) Outdoor unit higher than indoor unit: 49 (15)			
Operation range	Cooling	°F (°C)	14 to 115 (-10 to 46)			
	Heating		-13 to 75 (-25 to 24)			

NOTES:

- Specifications are based on the following conditions:
 - Cooling: Indoor temperature of 80 °FDB (26.67 °CDB) / 67 °FWB (19.44 °CWB), and outdoor temperature of 95 °FDB (35 °CDB) / 75 °FWB (23.9 °CWB).
 - Heating: Indoor temperature of 70 °FDB (21.11 °CDB) / 59 °FWB (15 °CWB), and outdoor temperature of 47 °FDB (8.33 °CDB) / 43 °FWB (6.11 °CWB).
 - Pipe length: 24 ft 6 in (7.5 m), Height difference: 0 ft (0 m). (Between outdoor unit and indoor unit.)
- Protective function might work when using it outside the operation range.
- *1: Sound pressure level
 - Measured values in manufacturer's anechoic chamber.
 - Because of the surrounding sound environment, the sound levels measured in actual installation conditions might be higher than the specified values here.

Type			Inverter heat pump			
Model name			WHP36M4A21S		WHP42M5A21S	
Power supply			208/230 V ~ 60 Hz			
Available voltage range			198—253 V			
Connectable indoor unit	Number		2 to 4		3 to 5	
	Total capacity range		30,000 to 46,000 Btu/h		34,000 to 54,000 Btu/h	
Standard combination of indoor unit			WHP09WMA21S × 4		WHP07WMA21S × 1 WHP09WMA21S × 4	
Capacity	Cooling	Rated	Btu/h	32,000	42,000	
			kW	9.379	12.309	
		Min.—Max.	Btu/h	12,000—42,000	9,000—50,000	
	Heating	Rated	kW	3.52—12.31	2.637—14.654	
			Btu/h	36,000	42,000	
		Min.—Max.	kW	10.551	12.309	
Input power	Cooling	Rated	kW	2.55	4.02	
				Min.—Max.	0.69—5.01	0.66—5.55
		Heating		Rated	3.12	3.87
	Heating	Rated		0.60—6.00	0.54—6.45	
				Min.—Max.	11.0	17.5
		Heating		Rated	13.0	17.0
EER	Cooling	Cooling	W/W	3.68	3.06	
			Btu/hW	12.55	10.50	
			W/W	3.38	3.18	
COP	Heating	Heating	Btu/hW	11.54	10.85	
			Btu/hW	21.0	20.0	
SEER	Cooling	Cooling	Btu/hW	11.0	10.0	
Fan	Airflow rate		CFM (m ³ /h)	3,413 (5,800)		
	Type × Q'ty		Propeller fan × 1			
	Motor output		W	138		
Sound pressure level *1			dB (A)	59		
Heat exchanger type	Dimensions (H × W × D)	in (mm)	39-11/16 × 38-3/16 × 11/16 (1,008 × 970 × 18.19)			
			39-11/16 × 38-3/16 × 11/16 (1,008 × 970 × 18.19)			
	Fin pitch	FPI	17			
	Rows × Stages	2 × 46				
	Pipe type	Copper				
Fin type	Type (Material)	Aluminum				
	Surface treatment	Blue fin				
Compressor	Type	Rotary				
Refrigerant	Type	R410A				
	Charge	lb oz	6 lb 10 oz	7 lb 8 oz		
		g	3,000	3,400		
Refrigerant oil	Type	VG74 (POE)				
Enclosure	Material	Steel sheet				
	Color	White				
Dimensions (H × W × D)	Net	in (mm)	41-5/16 × 37-3/8 × 13-3/8 (1,050 × 950 × 340)			
	Gross		47-1/4 × 43-11/16 × 18-1/8 (1,200 × 1,110 × 460)			
Weight	Net	lb (kg)	188 (85.5)	198 (90)		
	Gross		220 (100)	234 (106)		
Connection pipe	Size	Liquid	in (mm)	Ø1/4 (Ø6.35)		
		Gas		Ø3/8 (Ø9.52)		
	Method		Flare			
	Pre-charge length	Total	ft (m)	98 (30)	123 (37.5)	
		Each		246 (75)	262 (80)	
	Max. length	Total		65 (20)		
Each		Indoor unit higher than outdoor unit: 49 (15) Outdoor unit higher than indoor unit: 49 (15)				
Max. height difference		14 to 115 (-10 to 46)				
Operation range	Cooling	°F (°C)	-13 to 75 (-25 to 24)		-4 to 75 (-20 to 24)	
	Heating					
NOTES:						
<ul style="list-style-type: none"> Specifications are based on the following conditions: <ul style="list-style-type: none"> Cooling: Indoor temperature of 80 °FDB (26.67 °CDB) / 67 °FWB (19.44 °CWB), and outdoor temperature of 95 °FDB (35 °CDB) / 75 °FWB (23.9 °CWB). Heating: Indoor temperature of 70 °FDB (21.11 °CDB) / 59 °FWB (15 °CWB), and outdoor temperature of 47 °FDB (8.33 °CDB) / 43 °FWB (6.11 °CWB). Pipe length: 24 ft 6 in (7.5 m), Height difference: 0 ft (0 m). (Between outdoor unit and indoor unit.) Protective function might work when using it outside the operation range. *1: Sound pressure level <ul style="list-style-type: none"> Measured values in manufacturer's anechoic chamber. Because of the surrounding sound environment, the sound levels measured in actual installation conditions might be higher than the specified values here. 						

Dimensions

Wall mounted type

■ Models: WHP07WMA21S, WHP09WMA21S, and WHP12WMA21S

Unit: in (mm)

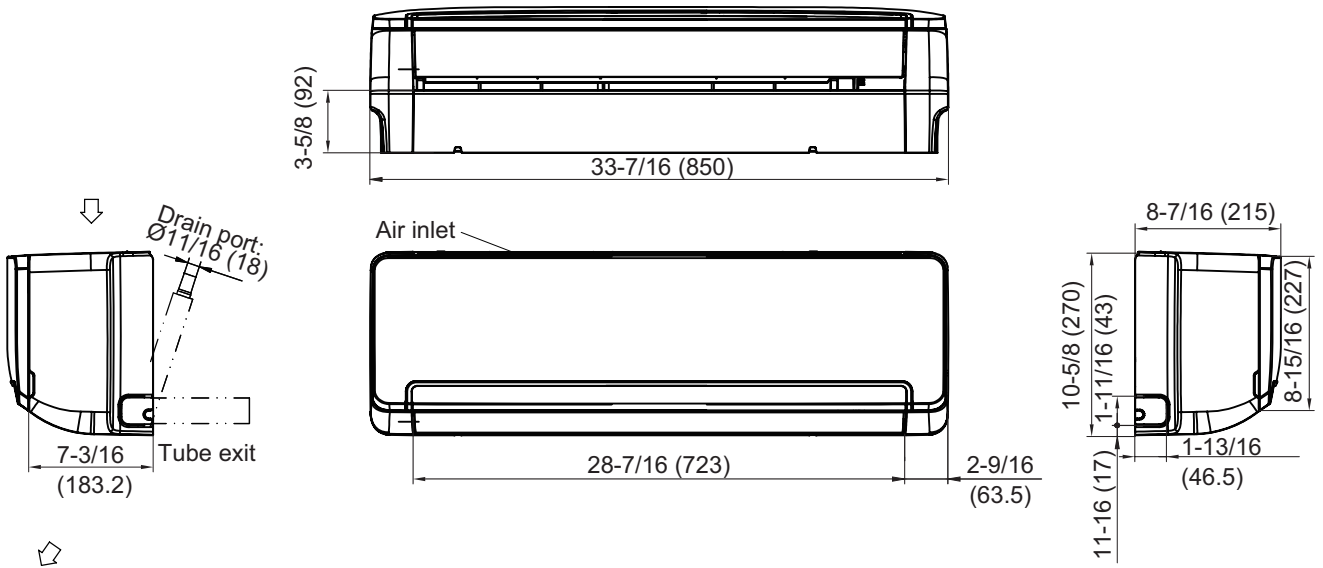

■ Models: WHP18WMA21S and WHP24WMA21S

Unit: in (mm)

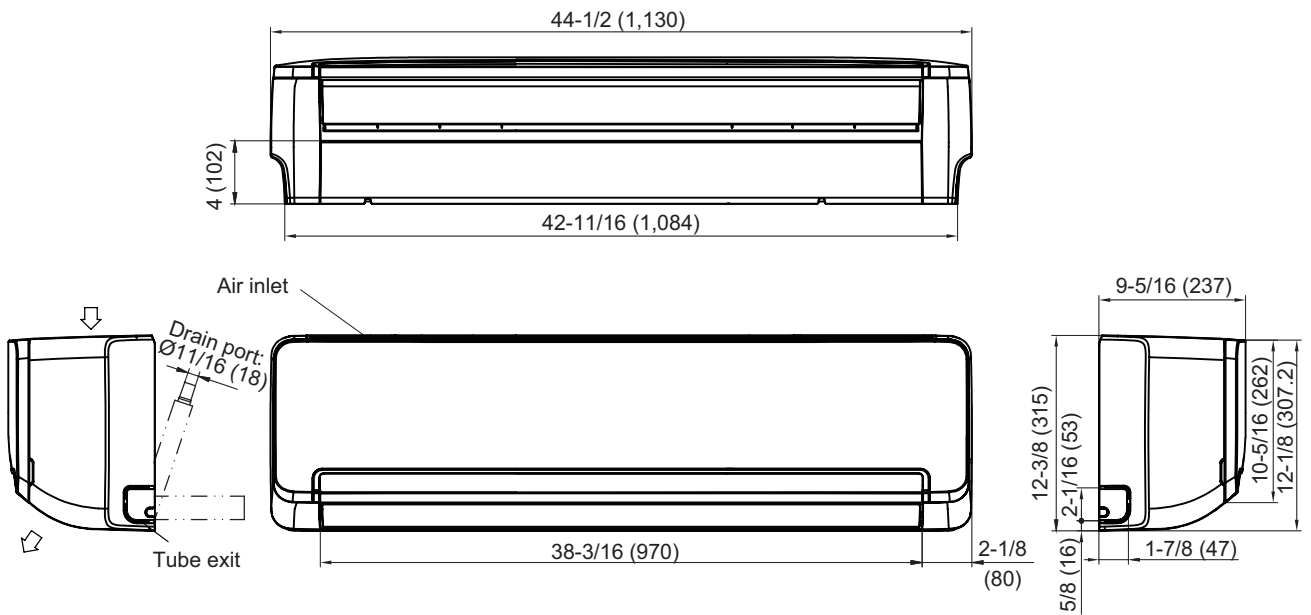

■ Installation space requirement

Provide sufficient installation space for product safety.

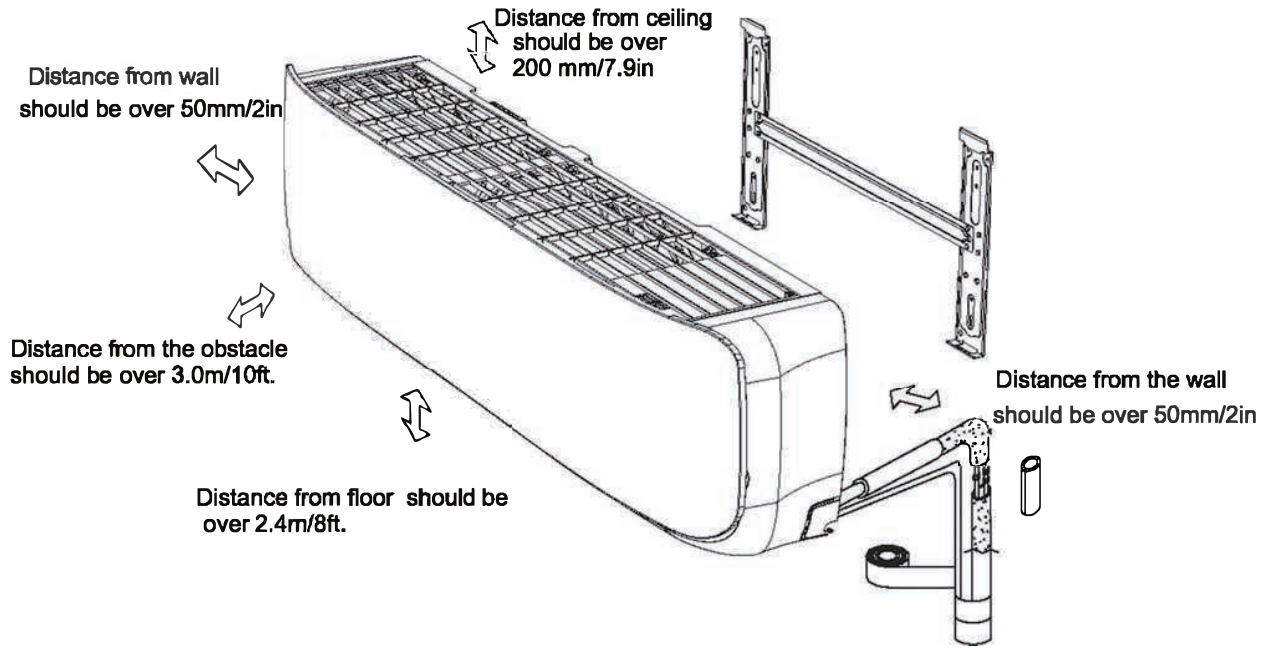

Cassette type

Models: WHU09CTA21S and WHU12CTA21S

Unit: in (mm)

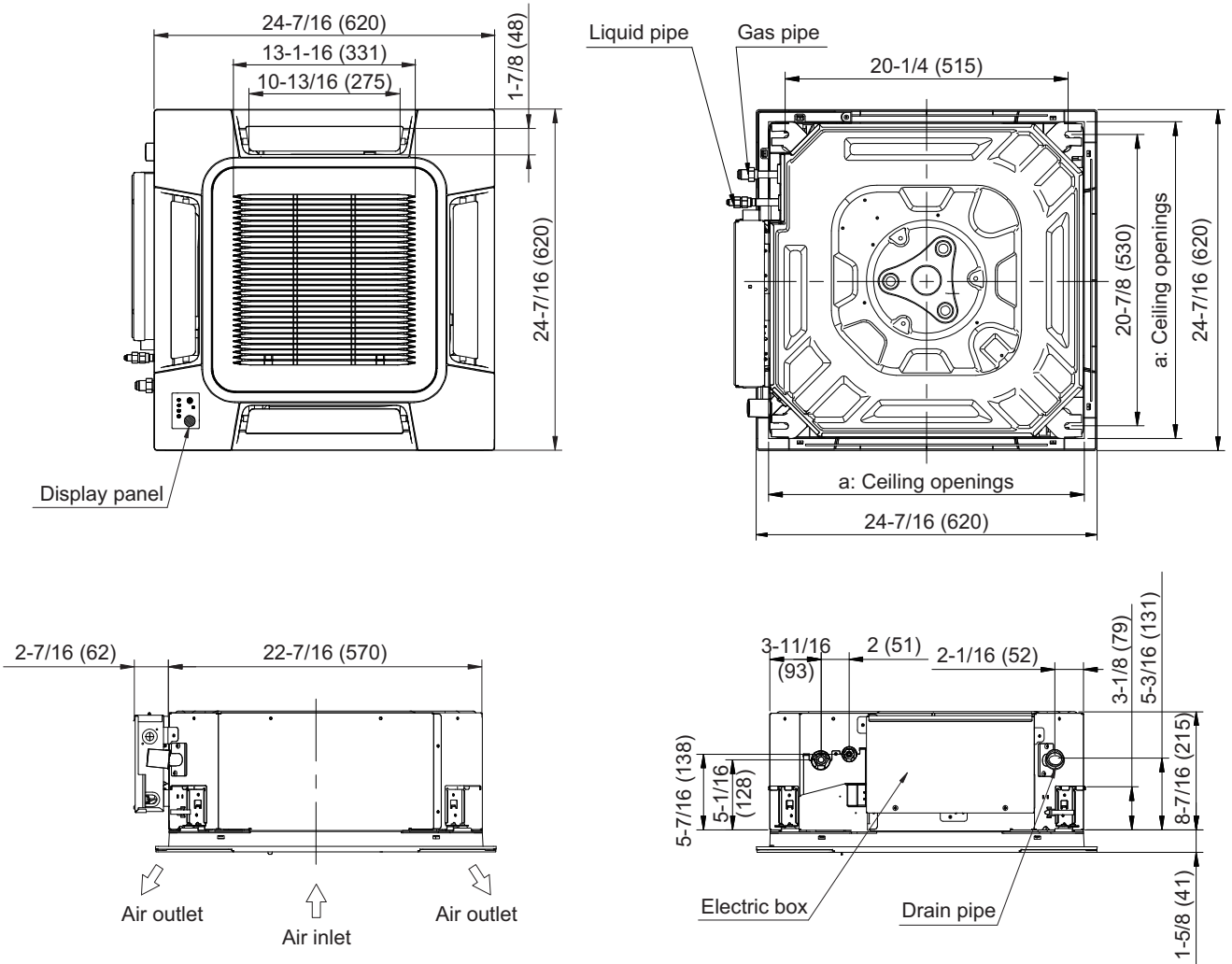

a: Ceiling openings		
Cassette grille (Option [Grid type])	in (mm)	22-5/8 to 23-1/4 (575 to 590)

■ Installation space requirement

Provide sufficient installation space for product safety.

Unit: in (mm)

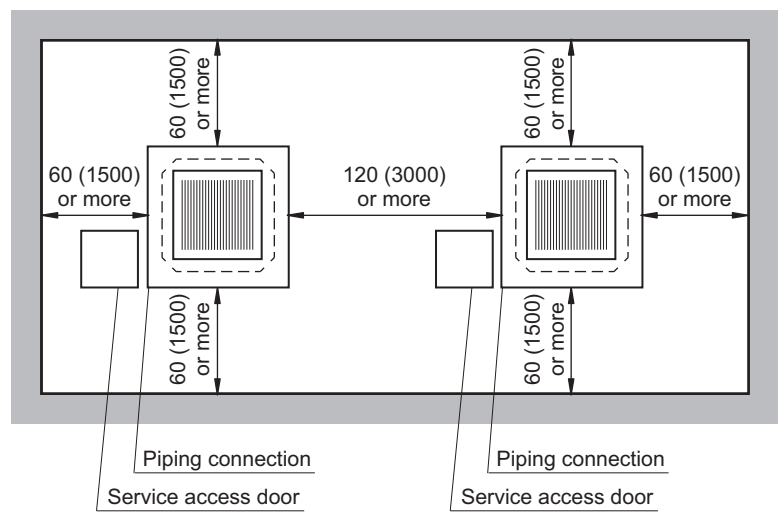
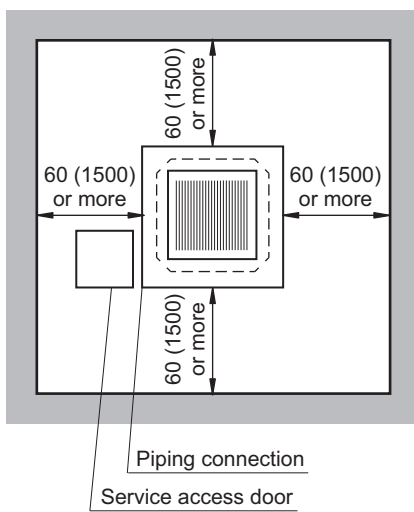
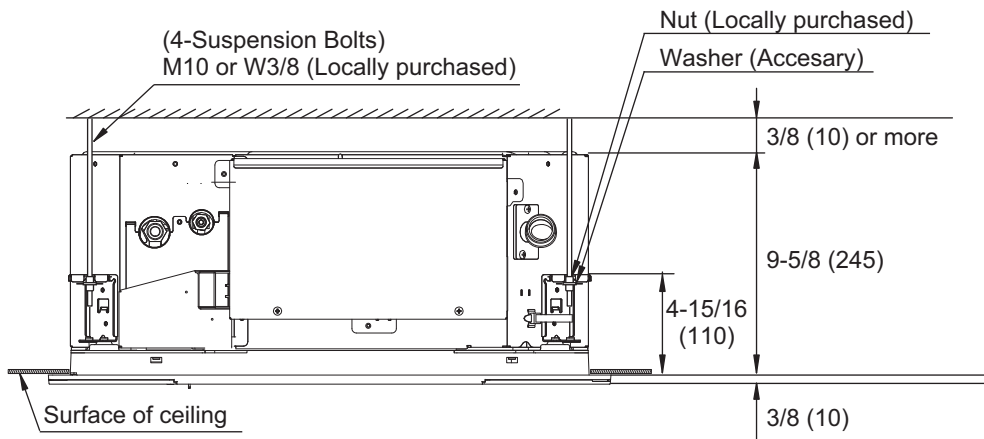

Models: WHU18CTA21S and WHU24CTA21S

Unit: in (mm)

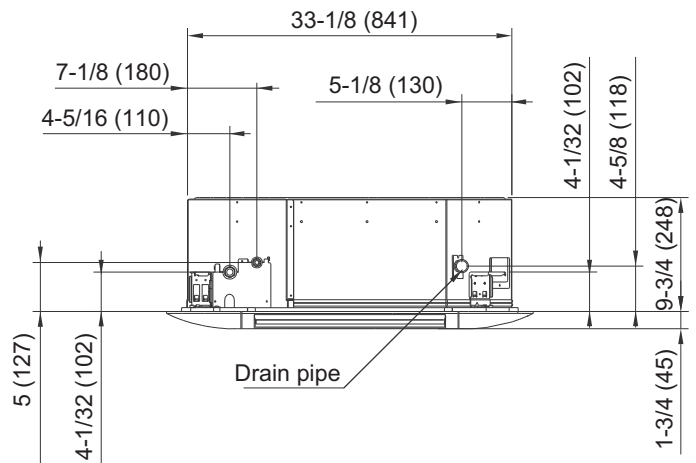
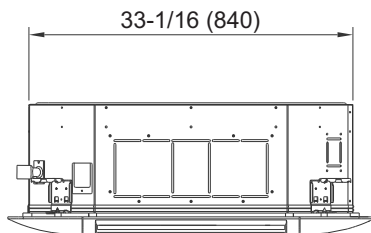
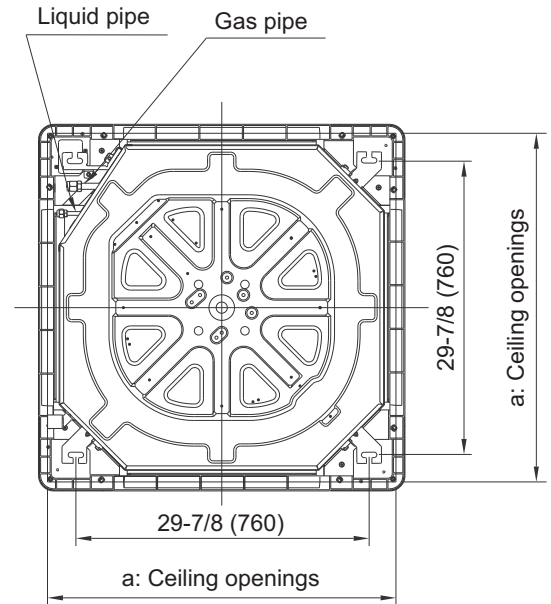
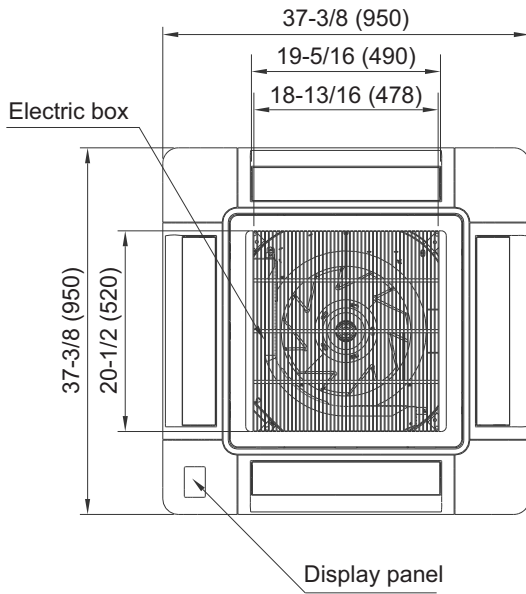

a: Ceiling openings		
Cassette grille (Option [Grid type])	in (mm)	$33\text{-}7/8$ to $35\text{-}13/16$ (860 to 910)

■ Installation space requirement

Provide sufficient installation space for product safety.

Unit: in (mm)

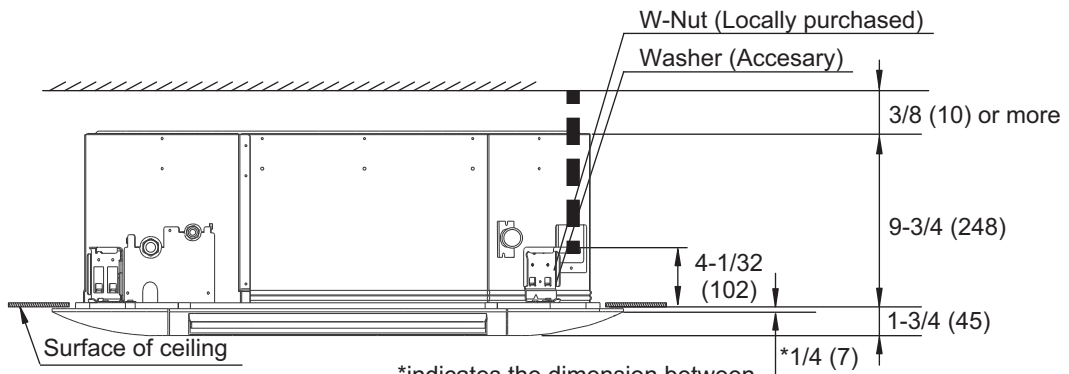

*indicates the dimension between lower face of indoor unit and surface of ceiling.

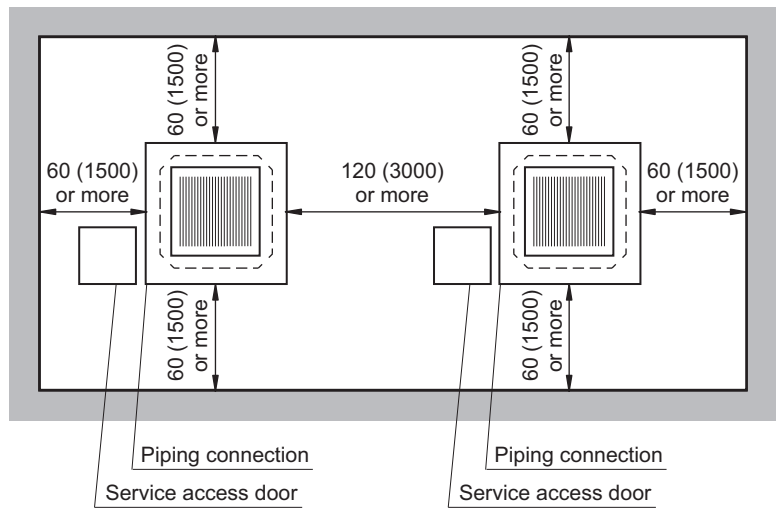
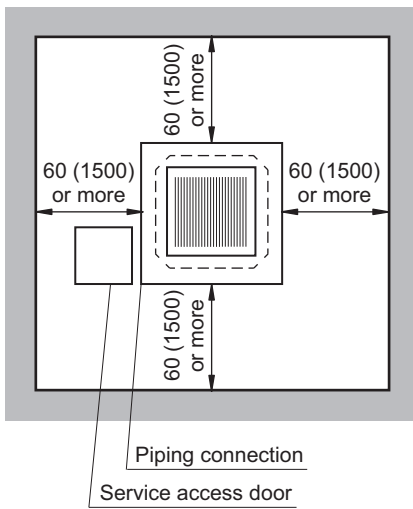

Duct type

■ Models: WHU09DHA21S and WHU12DHA21S

Unit: in (mm)

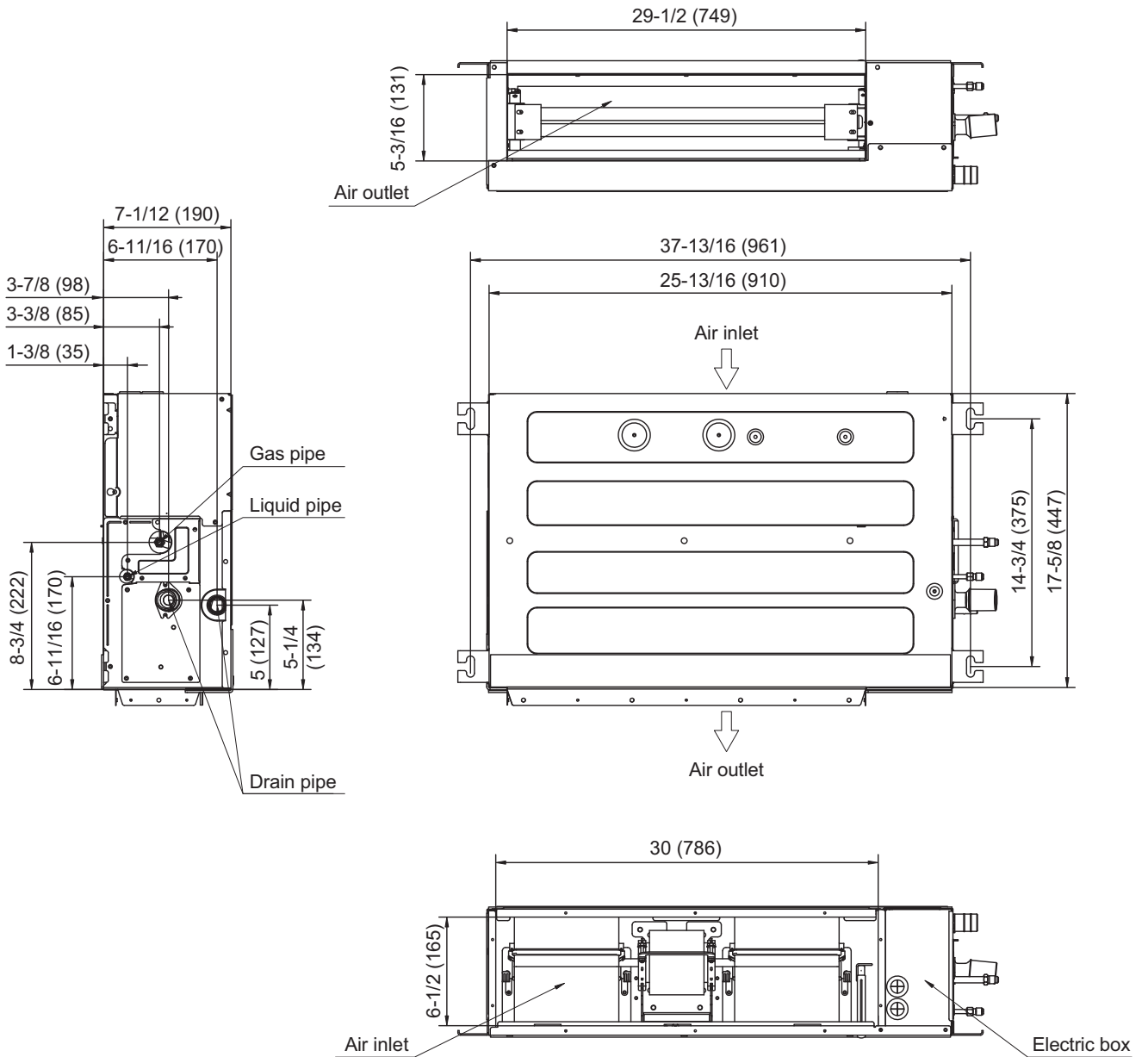

■ Model: WHU18DHA21S

Unit: in (mm)

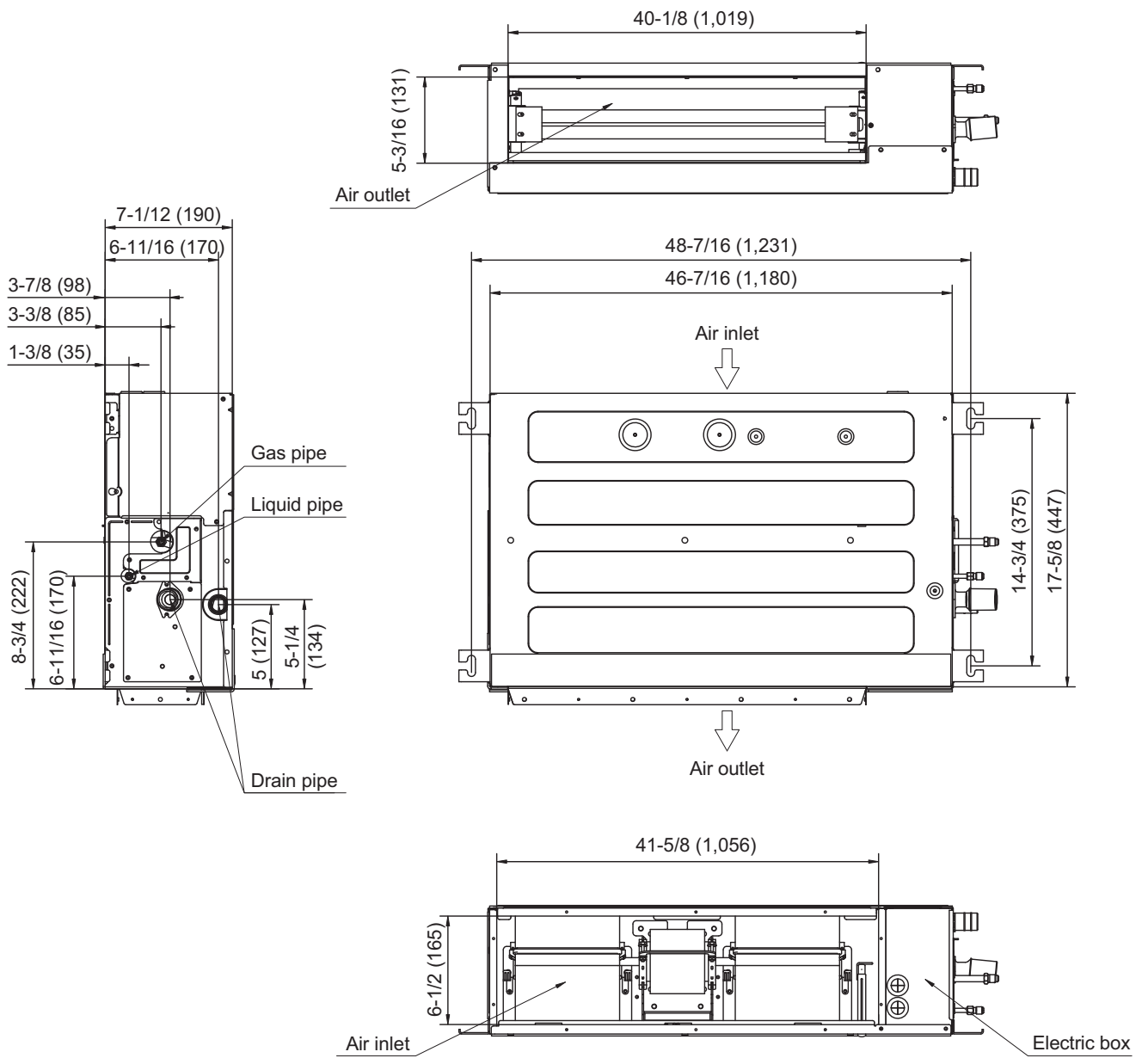

■ Installation space requirement

Provide sufficient installation space for product safety.

Unit: in (mm)

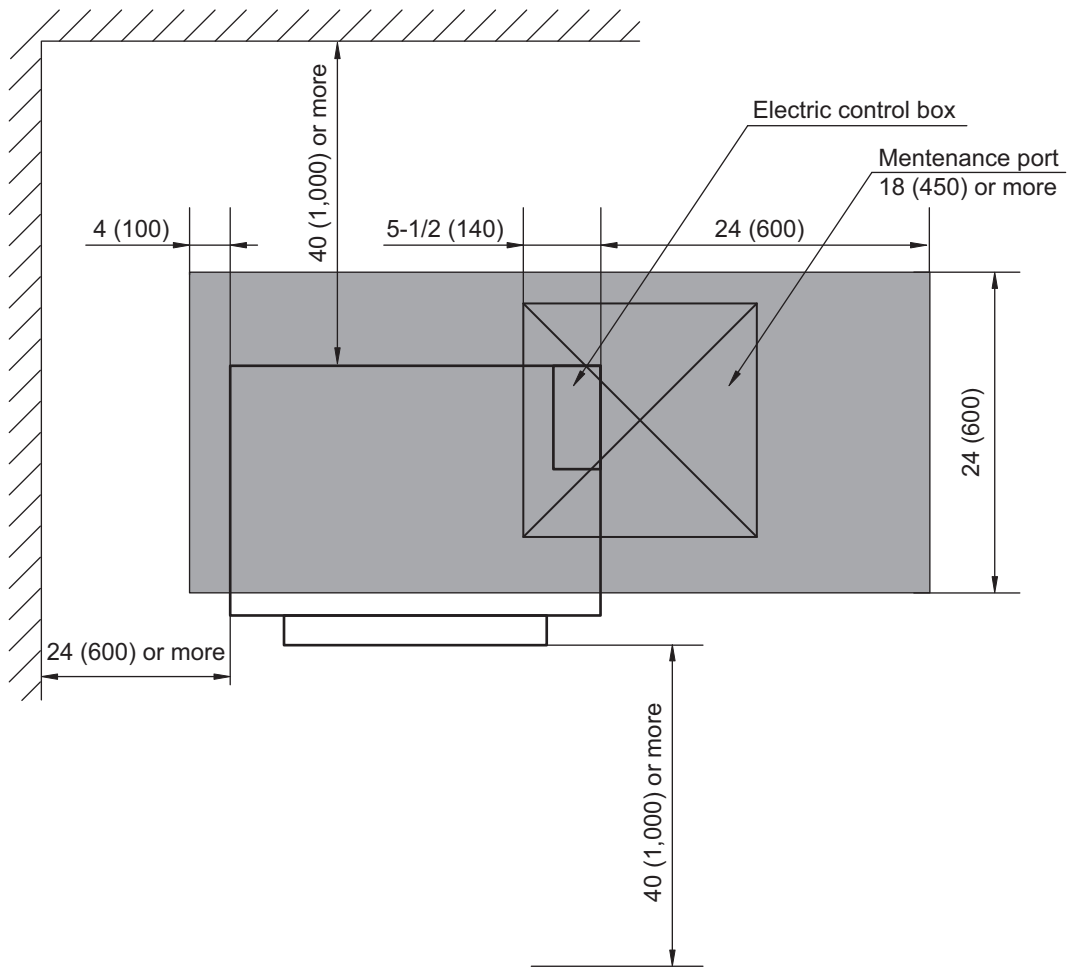

Top view

Model: WHU24DHA21S

Unit: in (mm)

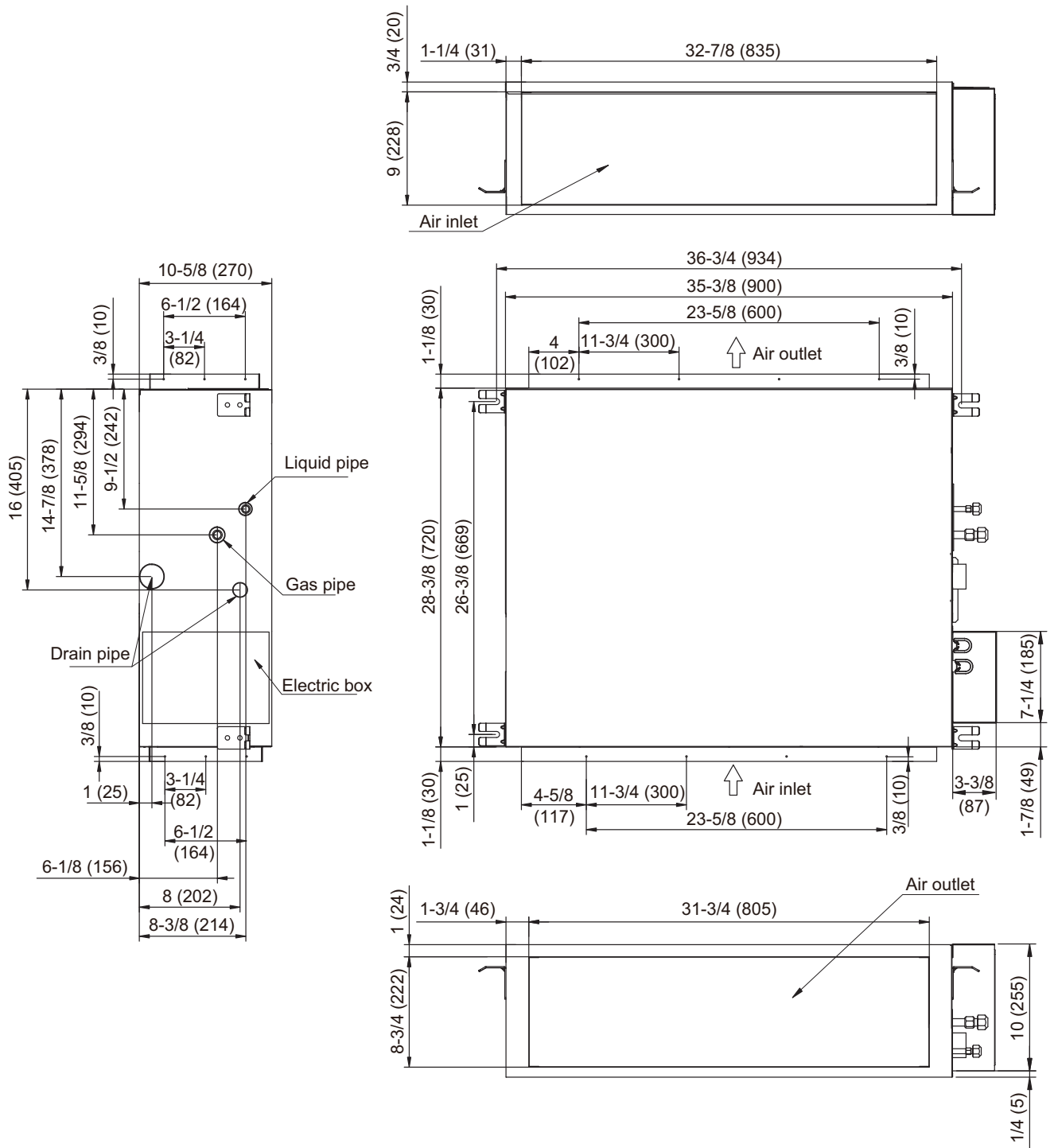

■ Installation space requirement

Provide sufficient installation space for product safety.

Unit: in (mm)

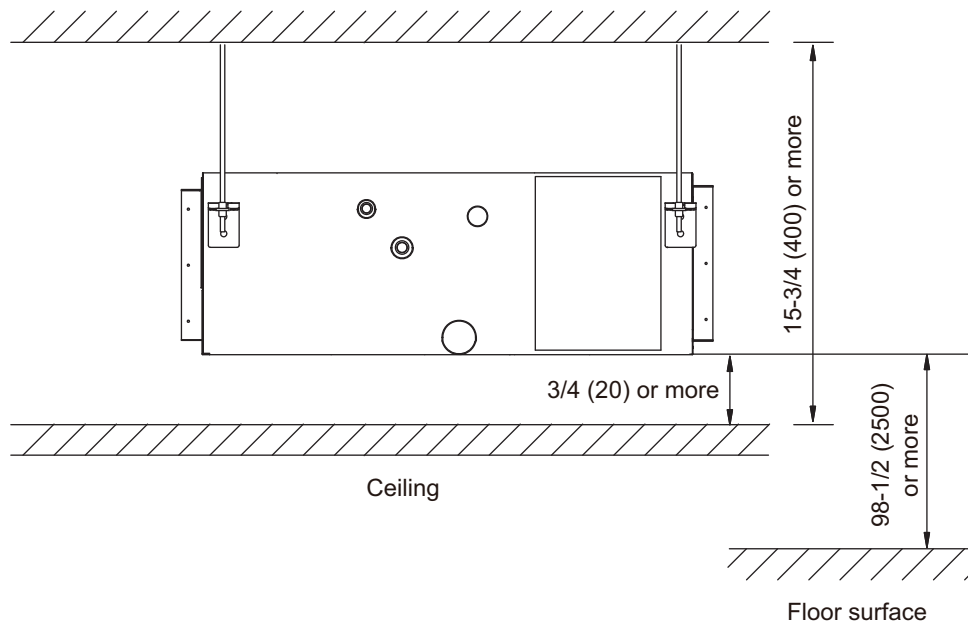
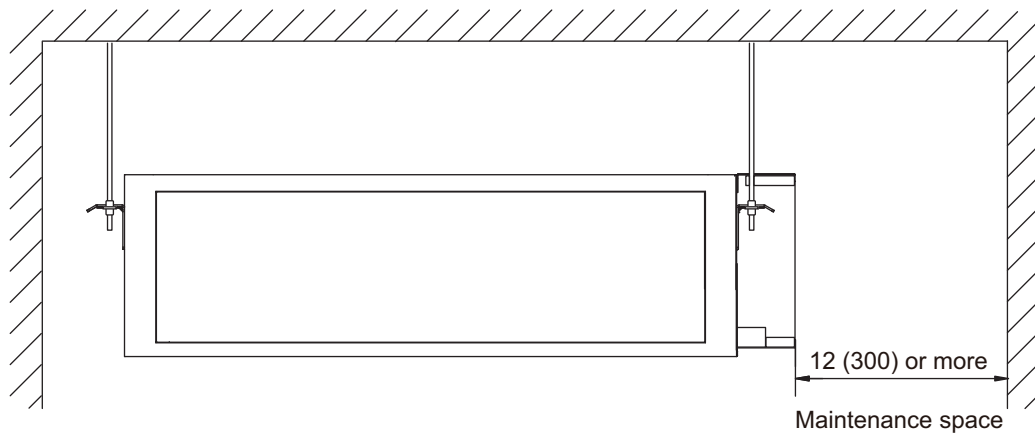

Outdoor unit

Model: WHP18M2A21S

Unit: in (mm)

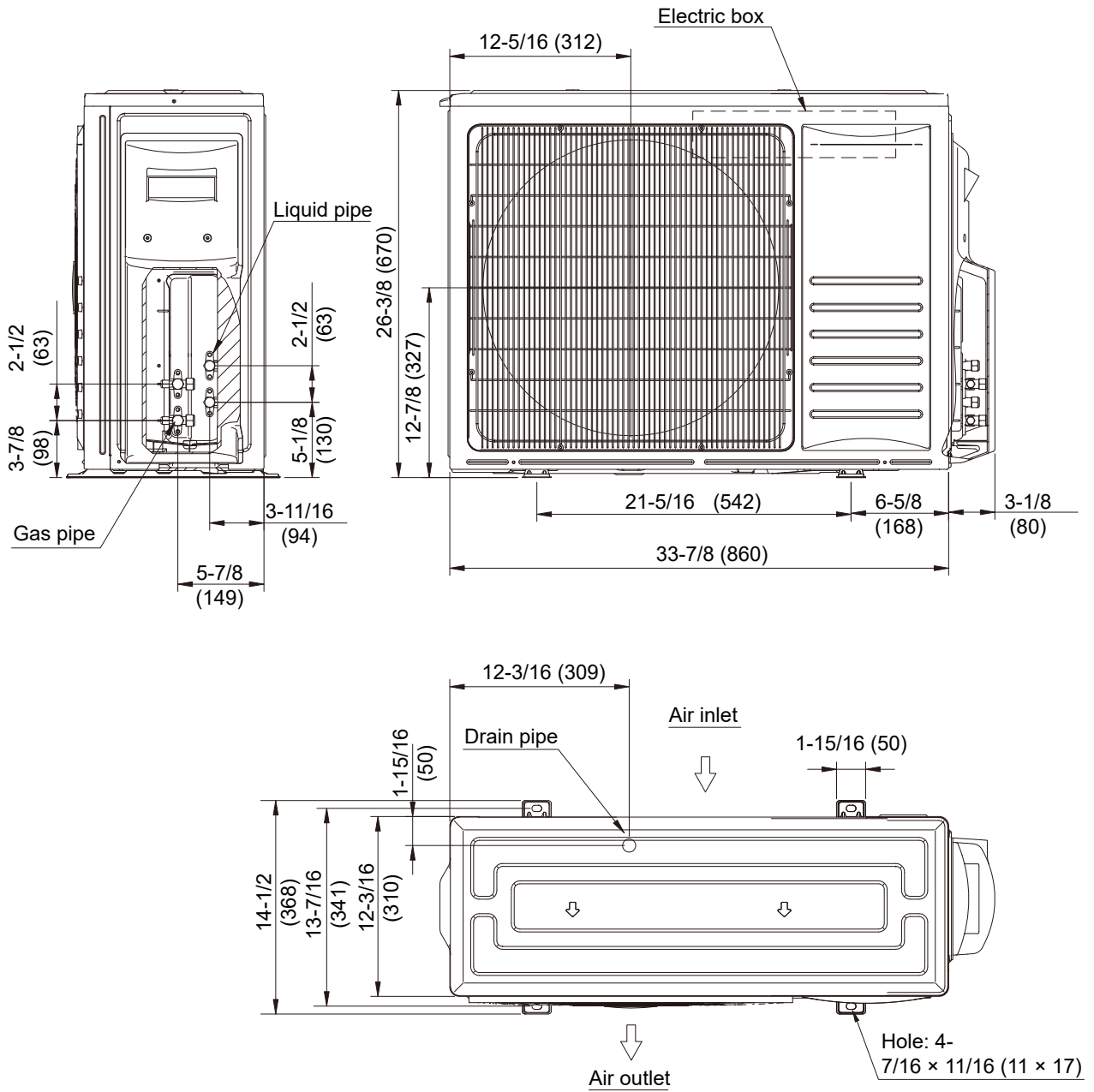

■ Model: WHP24M3A21S

Unit: in (mm)

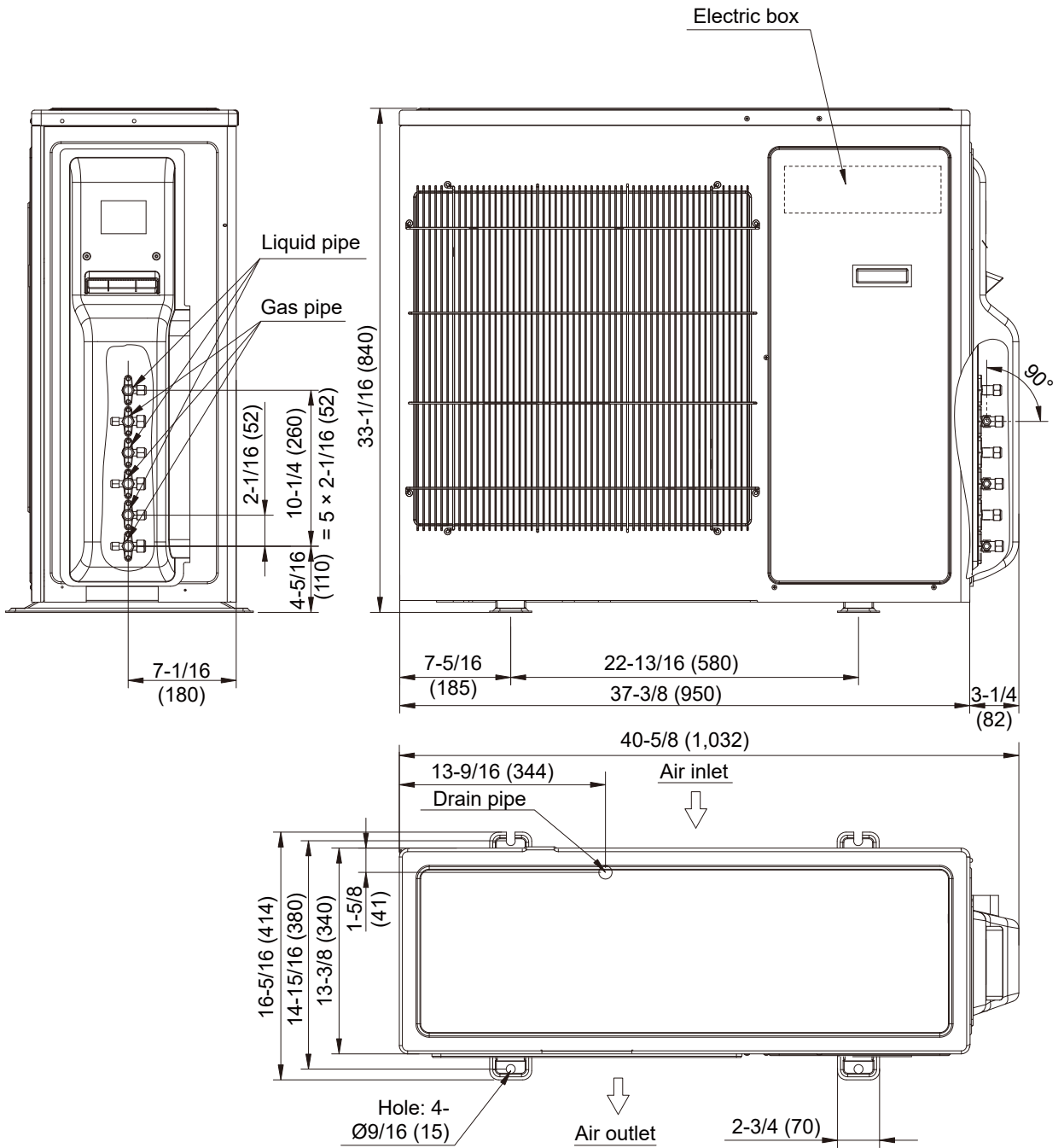

■ Models: WHP36M4A21S and WHP42M5A21S

Unit: in (mm)

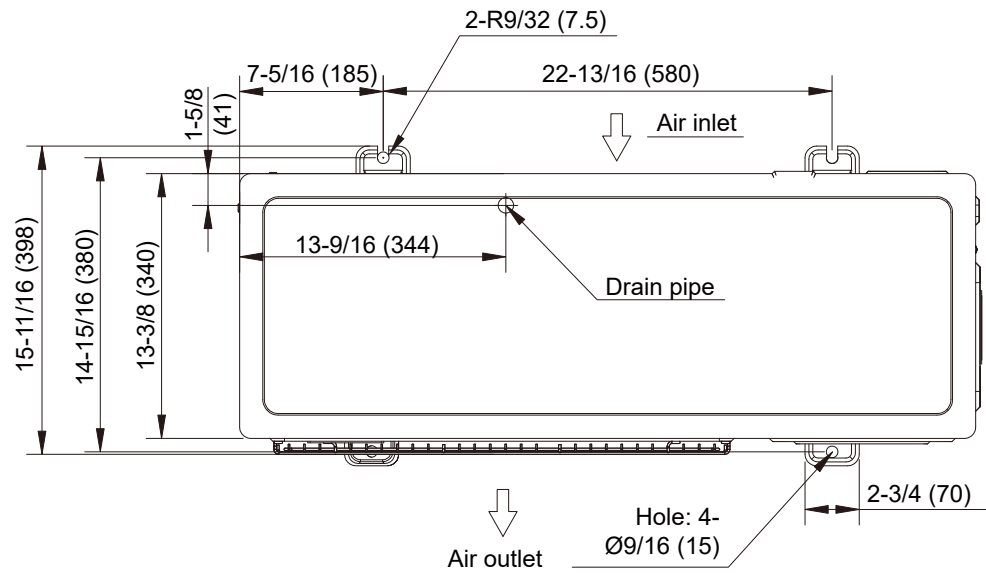
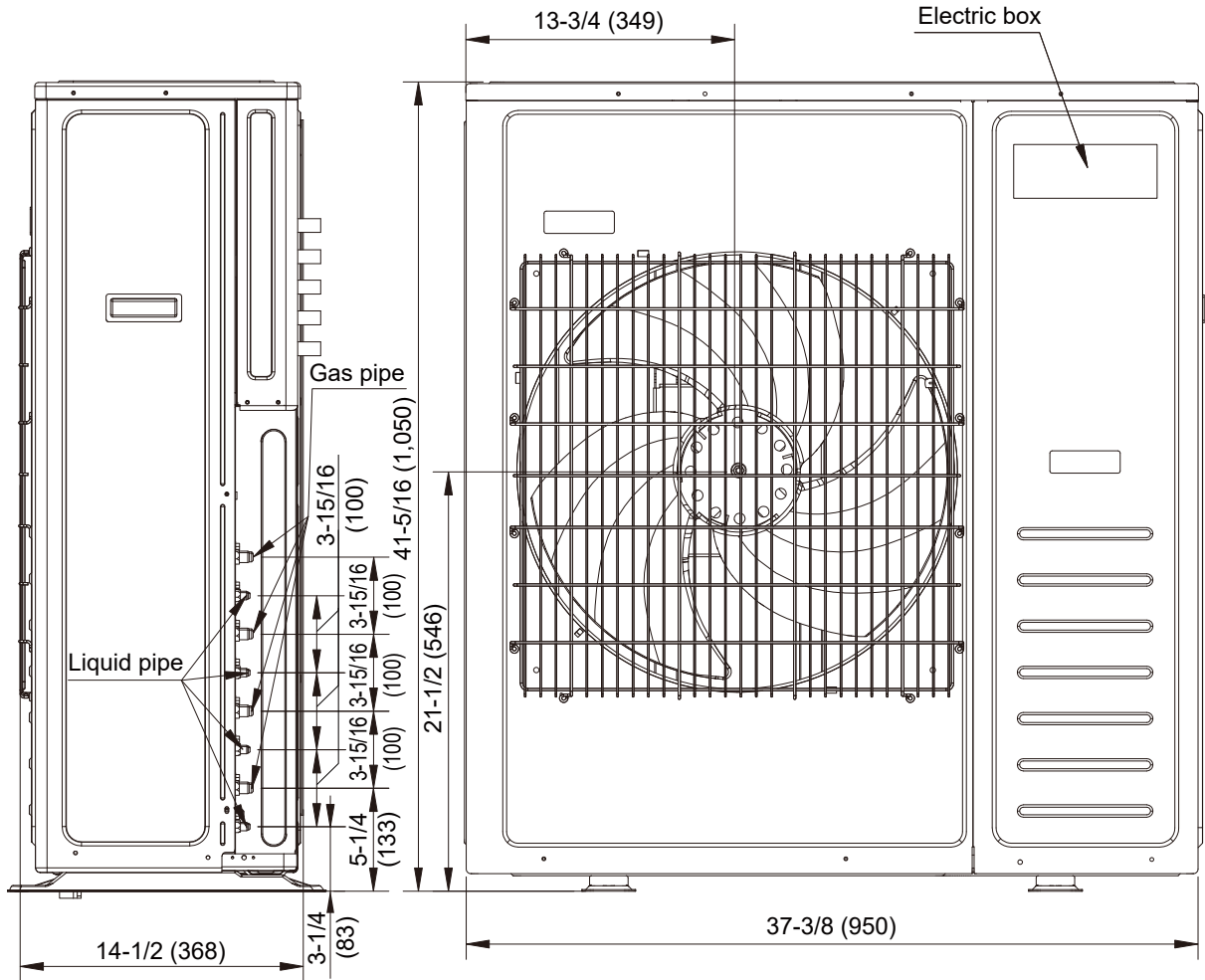

Installation space

Models: WHP18M2A21S, WHP24M3A21S, WHP36M4A21S, and WHP42M5A21S

■ Space requirement

Provide sufficient installation space for product safety.

⚠ CAUTION

Keep the space shown in the installation examples.

If the installation is not performed accordingly, it could cause a short circuit and result in a lack of operating performance.

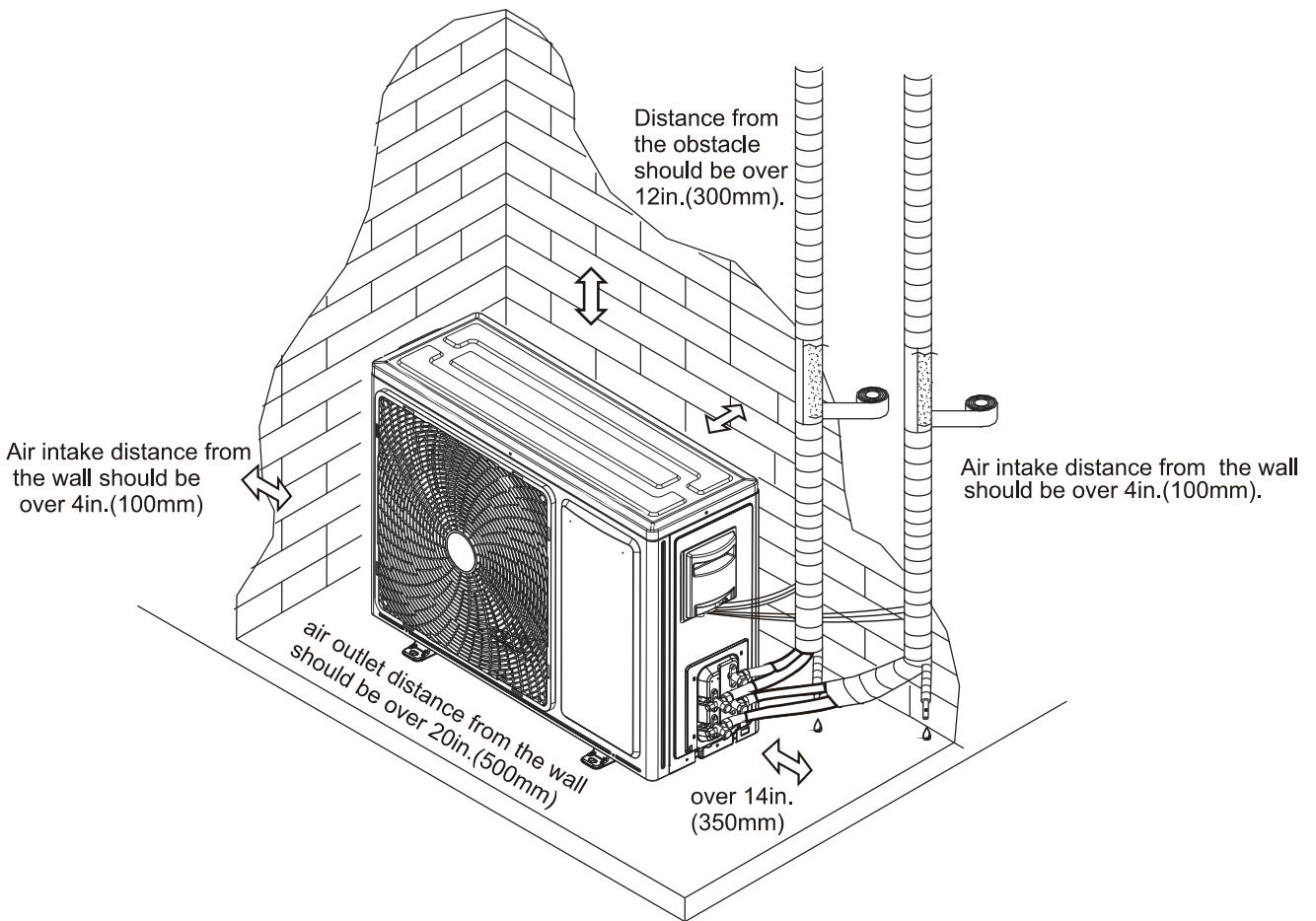

- **Refrigerant piping**

Refrigerant pipe should be as short as possible.

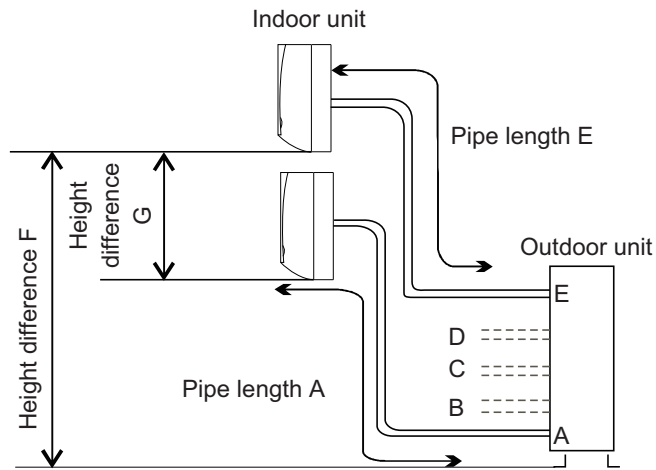

	Unit	18 model	24 model	36 model	42 model
Maximum length between indoor unit and outdoor unit (A/B/C/D/E)	ft (m)	≤ 82 (25)	≤ 65 (20)		
Total length of piping between all units		A + B ≤ 164 (50)	A + B + C ≤ 196 (60)	A + B + C + D ≤ 246 (75)	A + B + C + D + E ≤ 262 (80)
Maximum height difference between indoor unit and outdoor unit (F)		≤ 49 (15)			
Maximum height difference between indoor units (G)		≤ 24 (7.5)			

Additional refrigerant charge

When the total pipe length (L) exceeds standard length, additional refrigerant charge is required.

Model	Required amount of additional refrigerant
WHP18M2A21S	(L - 49 ft [15 m]) × 0.807 oz/ft (15 g/m)
WHP24M3A21S	(L - 73 ft [22.5 m]) × 0.807 oz/ft (15 g/m)
WHP36M4A21S	(L - 98 ft [30 m]) × 0.807 oz/ft (15 g/m)
WHP42M5A21S	(L - 123 ft [37.5 m]) × 0.807 oz/ft (15 g/m)

Refrigerant circuit

Model: WHP18M2A21S

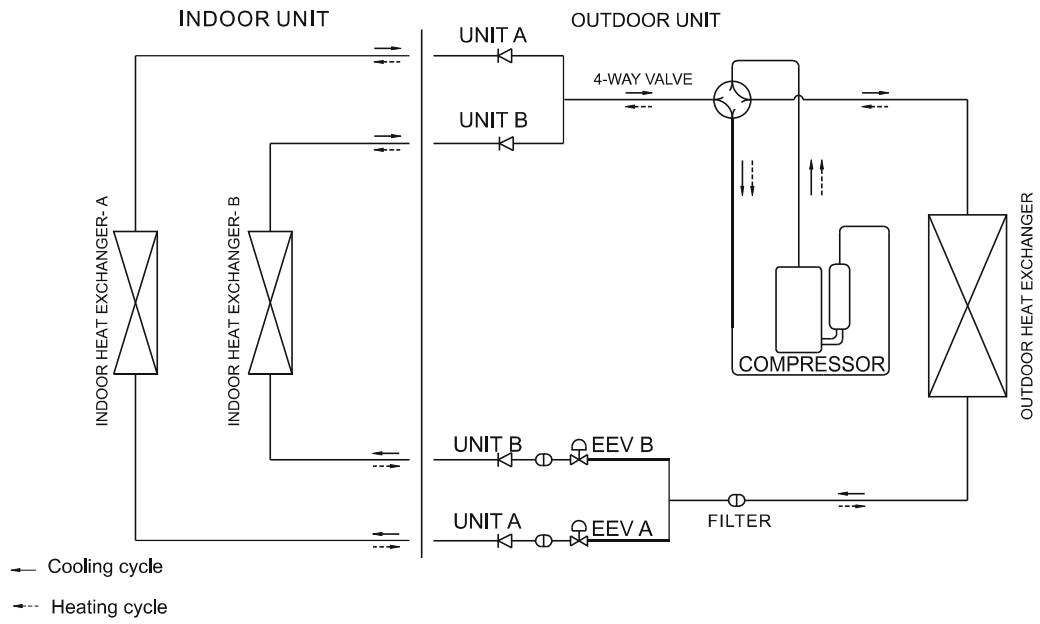

Model: WHP24M3A21S

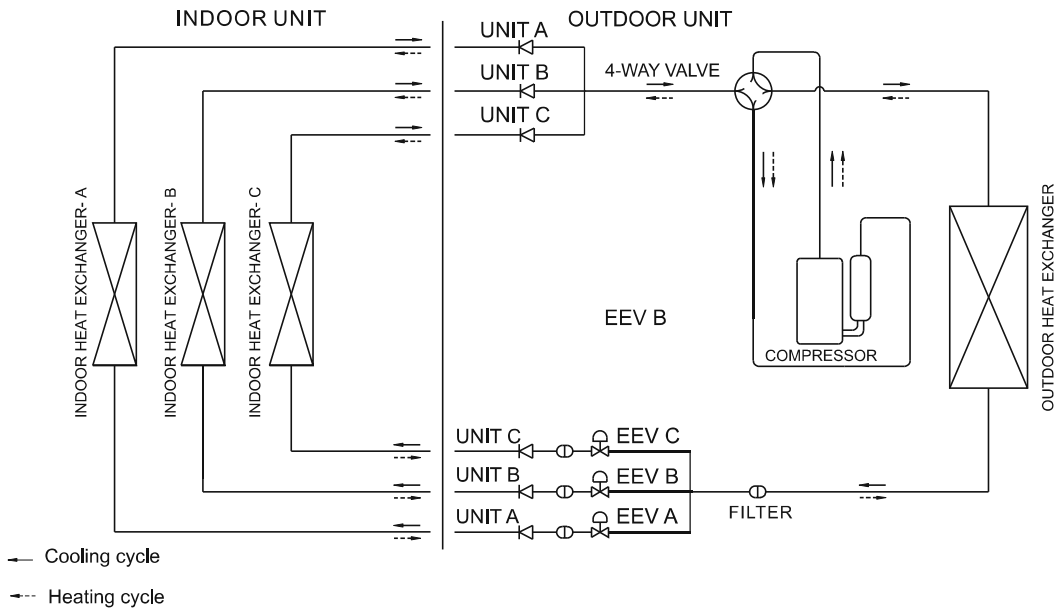

Model: WHP36M4A21S

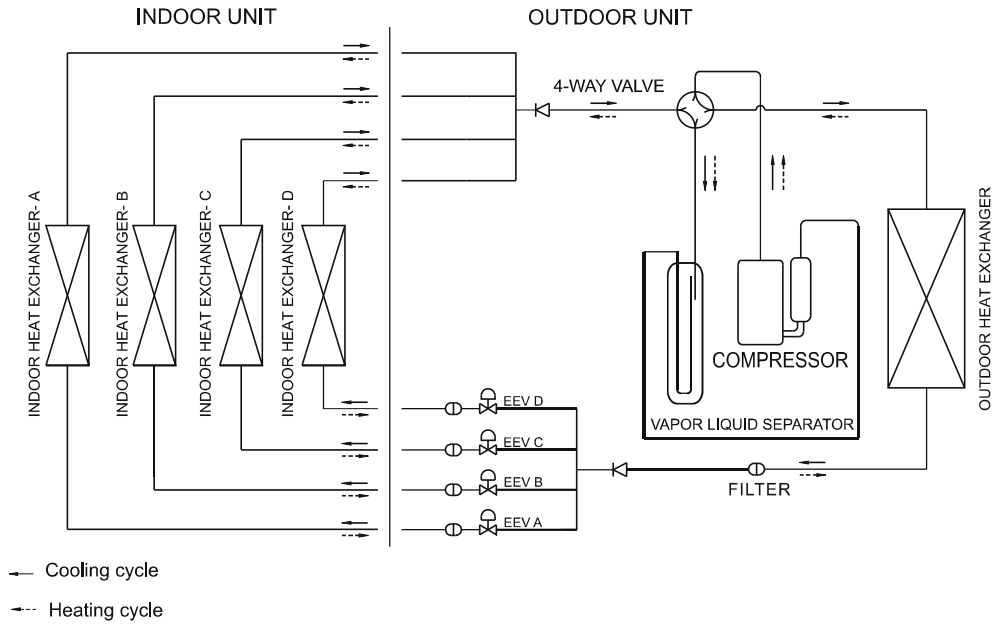

Model: WHP42M5A21S

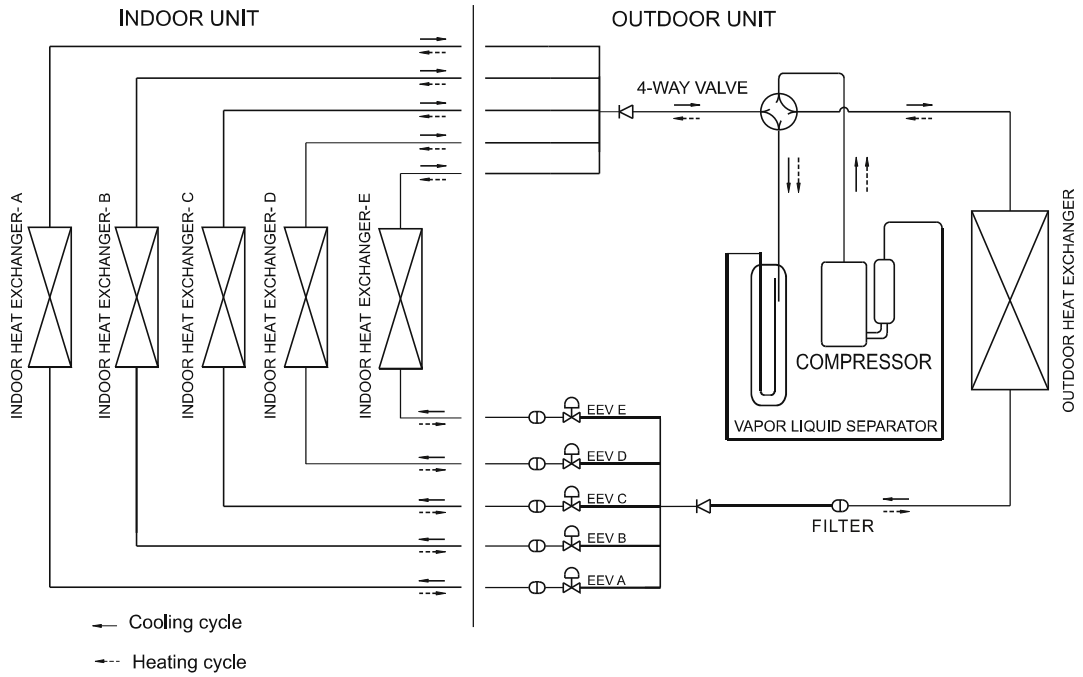

Wiring diagrams

Model: WHP18M2A21S

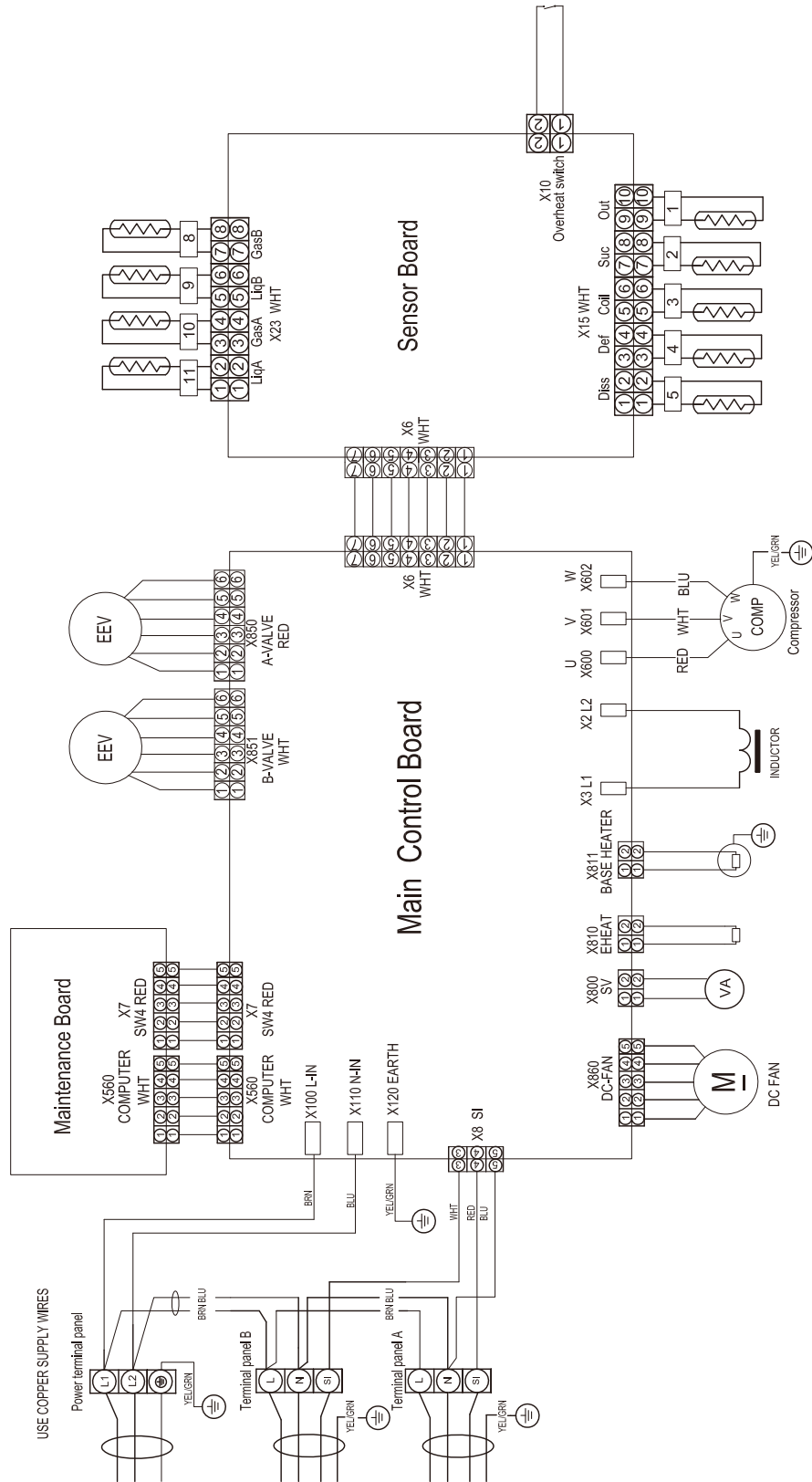

Model: WHP24M3A21S

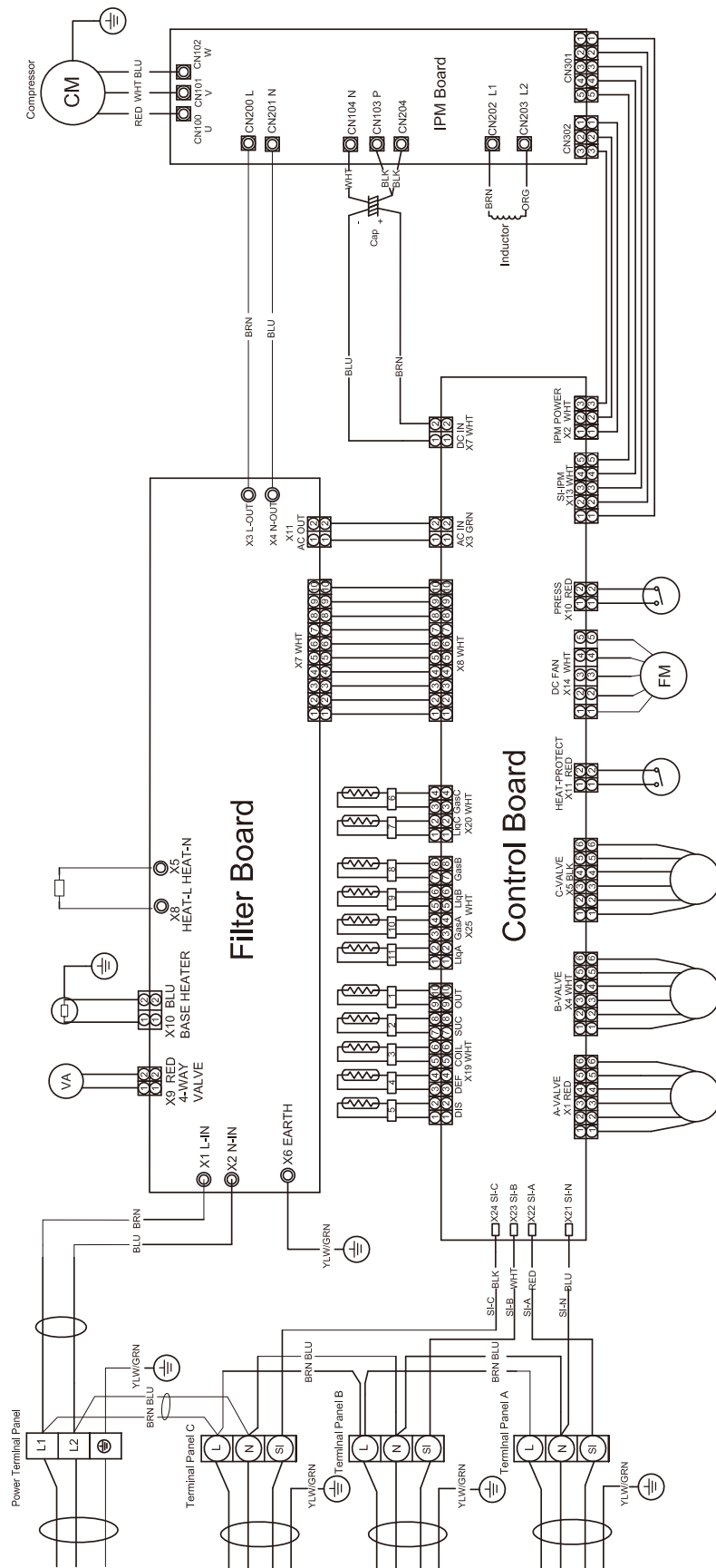

Model: WHP36M4A21S

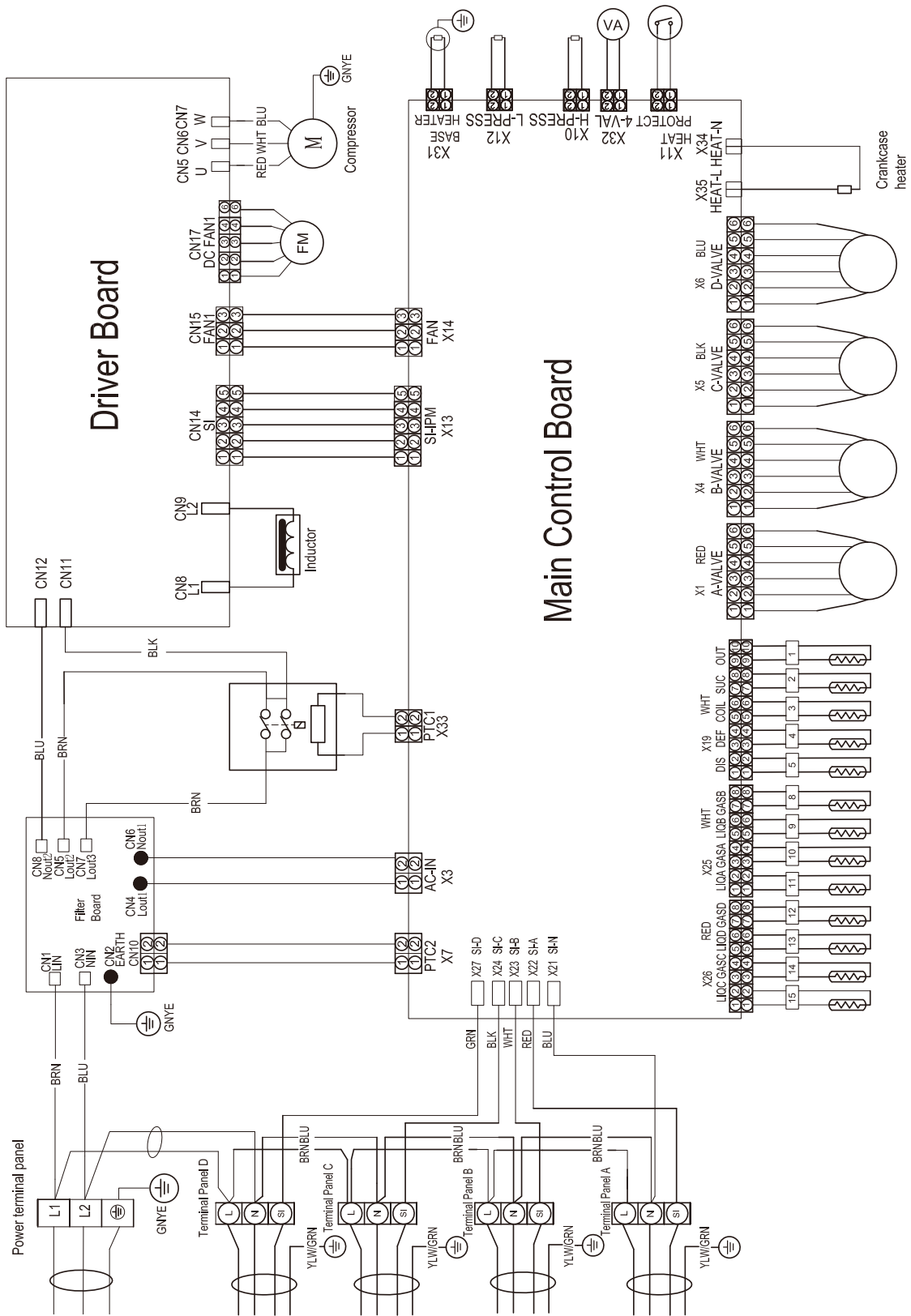

Model: WHP42M5A21S

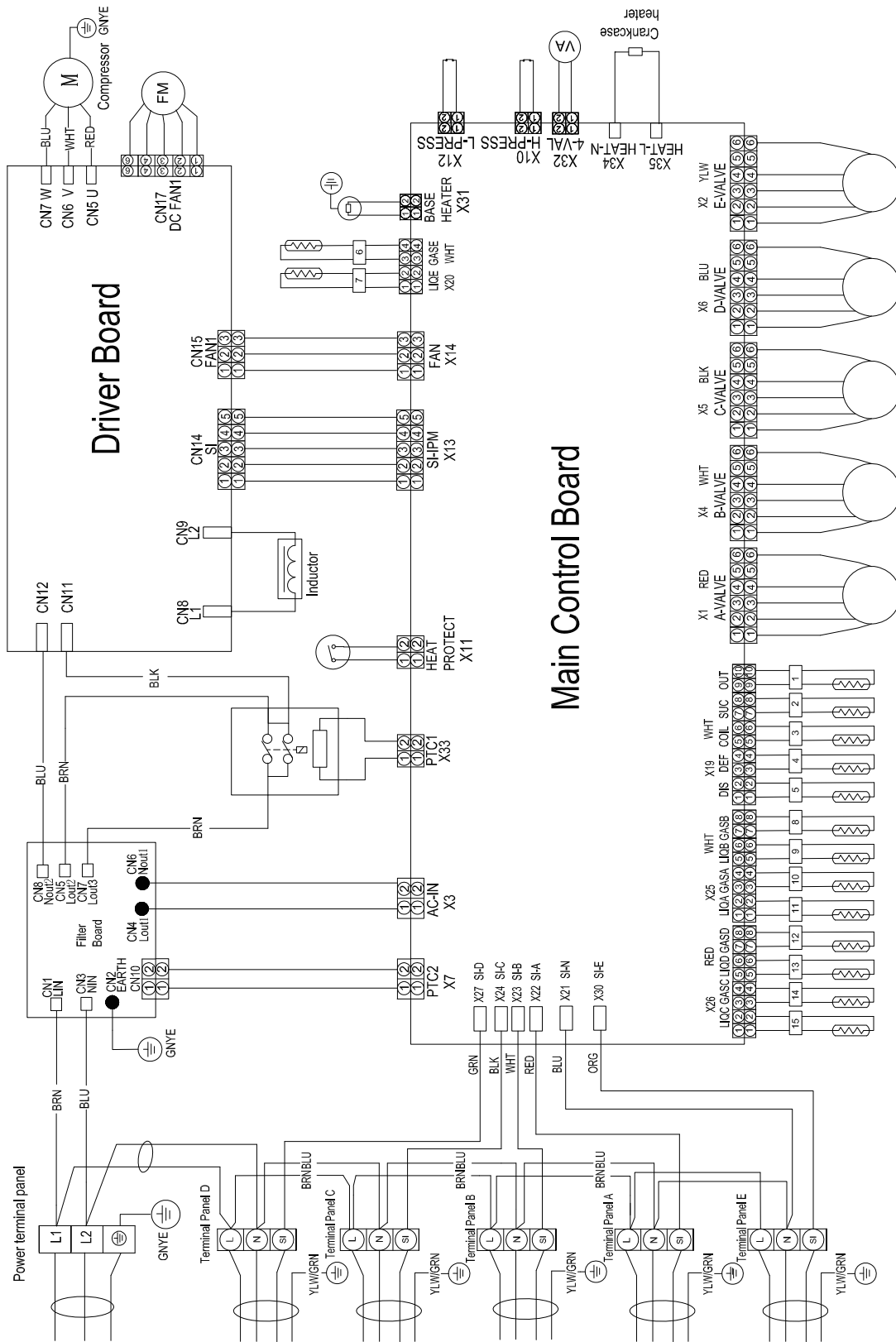



Field setting

Outdoor unit DIP switch

Dip Switch Setting of Outdoor Unit

Mark of "■" indicates the position of dip switches.
Switch is valid when is ON.

Dip switch S4	
Factory Setting	
Refrigerant Collection	
Manual Defrost	

Refrigerant collection function

By default setting is OFF.

OFF ----normal mode

ON----refrigerant collection mode

When the power is ON, the dial changed from OFF to ON, enters into refrigerant collection mode.

During refrigerant recovery mode, system low pressure protect will not occurs, and compressor will stops after 5 minutes, and will turn to normal state when power on again.

Manual defrost function

By default setting is OFF.

OFF ----normal mode

ON----defrost mode

When the dial changed from OFF to ON in heating mode, enters into defrost mode, and only valid once.

Running parameter query

Outdoor Running parameters can be checked by 7 segment display.

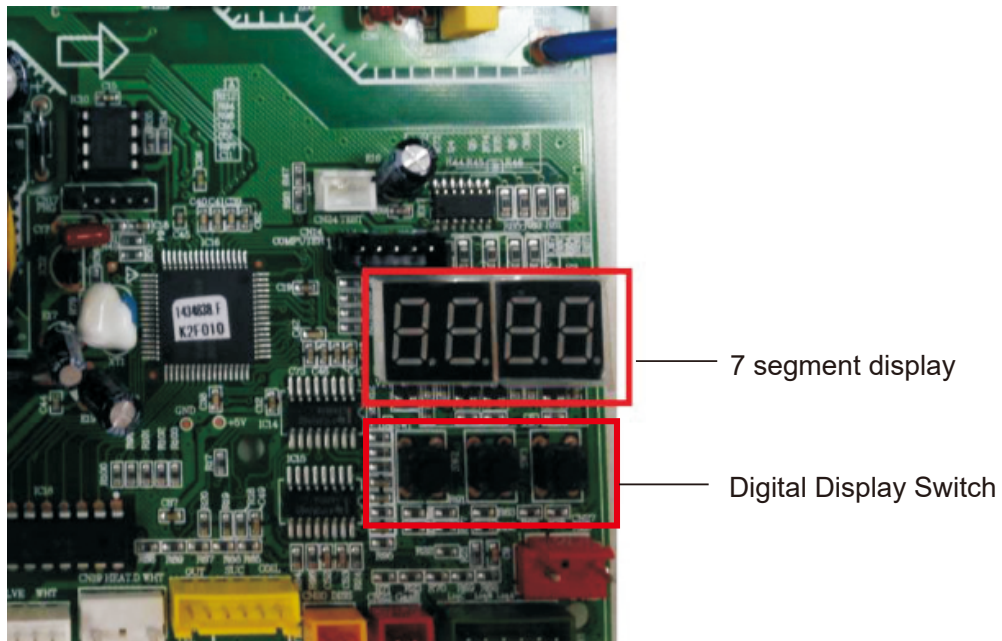

Outdoor control board

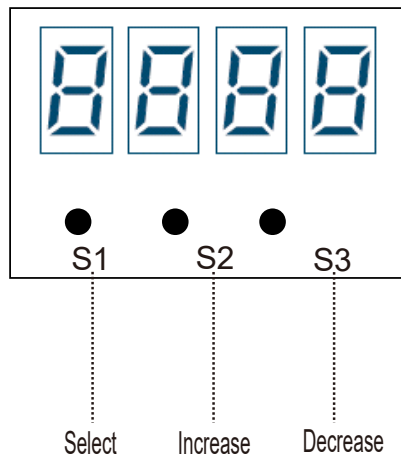

There are 3 buttons on the digital display board :

1) Select button: Select to display outdoor/indoor unit parameter.

- "P." -- Parameter of outdoor unit
- "A." -- Parameter of indoor unit A
- "b." -- Parameter of indoor unit B
- "C."-- Parameter of indoor unit C
- "d."-- Parameter of indoor unit D
- "E." -- Parameter of indoor unit E

2) INCREASE button : Each time it is pressed, the number rises by 1.

3) DECREASE button : Each time it is pressed, the number lowers by 1.

The parameter content will automatically displayed after the parameter code is selected for 3s.

Parameters can be checked as following table below.

Note:

(1) ●:Valid; ○: Invalid.

(2) The right is therefore reserved to EE changing without notice.

Field setting

Parameter	Descriptions	Dual	Trio	Quattro	1 by 5
P.0	Fault codes	●	●	●	●
P.1	Compressor actual frequency	●	●	●	●
P.2	Compressor driving frequency	●	●	●	●
P.4	Compressor target frequency	●	●	●	●
P.5	Compressor exhaust temperature	●	●	●	●
P.6	Outdoor suction Temperature	●	●	●	●
P.7	Outdoor ambient temperature	●	●	●	●
P.8	Outdoor coil temperature	●	●	●	●
P.9	Outdoor defrosting temperature	●	●	●	●
P.10	IPM module temperature	●	●	●	●
P.11	Outdoor capacity requirement	●	●	●	●
P.12	IPM fault codes	●	●	●	●
P.13	Outdoor DC Motor target speed	●	●	●	●
P.14	AC input current	●	●	●	●
P.15	AC input voltage	●	●	●	●
P.16	DC bus voltage	●	●	●	●
P.17	Compressor phase current	●	●	●	●
P.18	Frequency limit code	●	●	●	●
P.20	Target suction overheating	●	●	●	●
P.21	Target exhaust overheating	●	●	●	●
P.22	Actual suction overheating (heating)	●	●	●	●
P.23	Actual exhaust overheating (heating)	●	●	●	●
A.1	Unit A fault codes	●	●	●	●
A.2	Unit A valve actual opening	●	●	●	●
A.4	Unit A liquid pipe temperature	●	●	●	●
A.5	Unit A gas pipe temperature	●	●	●	●
A.6	Unit A coil temperature	●	●	●	●
A.7	Unit A ambient temperature	●	●	●	●
A.8	Unit A set temperature	●	●	●	●
A.9	Unit A capacity	●	●	●	●
A.10	Unit A set fan speed	●	●	●	●
A.11	Unit A actual suction overheating	●	●	●	●
B.1	Unit B fault codes	●	●	●	●
B.2	Unit B valve actual opening	●	●	●	●
B.4	Unit B liquid pipe temperature	●	●	●	●
B.5	Unit B gas pipe temperature	●	●	●	●
B.6	Unit B coil temperature	●	●	●	●
B.7	Unit B ambient temperature	●	●	●	●
B.8	Unit B set temperature	●	●	●	●
B.9	Unit B capacity	●	●	●	●
B.10	Unit B set fan speed	●	●	●	●
B.11	Unit B actual suction overheating	●	●	●	●
C.1	Unit C fault codes	○	●	●	●
C.2	Unit C valve actual opening	○	●	●	●
C.4	Unit C liquid pipe temperature	○	●	●	●
C.5	Unit C gas pipe temperature	○	●	●	●
C.6	Unit C coil temperature	○	●	●	●
C.7	Unit C ambient temperature	○	●	●	●
C.8	Unit C set temperature	○	●	●	●
C.9	Unit C capacity	○	●	●	●
C.10	Unit C set fan speed	○	●	●	●
C.11	Unit C actual suction overheating	○	●	●	●
D.1	Unit D fault codes	○	○	●	●
D.2	Unit D valve actual opening	○	○	●	●
D.4	Unit D liquid pipe temperature	○	○	●	●
D.5	Unit D gas pipe temperature	○	○	●	●
D.6	Unit D coil temperature	○	○	●	●
D.7	Unit D ambient temperature	○	○	●	●
D.8	Unit D set temperature	○	○	●	●
D.9	Unit D capacity	○	○	●	●
D.10	Unit D set fan speed	○	○	●	●
D.11	Unit D actual suction overheating	○	○	●	●

Parameter	Descriptions	Dual	Trio	Quattro	1 by 5
E.1	Unit E fault codes	○	○	○	●
E.2	Unit E valve actual opening	○	○	○	●
E.4	Unit E liquid pipe temperature	○	○	○	●
E.5	Unit E gas pipe temperature	○	○	○	●
E.6	Unit E coil temperature	○	○	○	●
E.7	Unit E ambient temperature	○	○	○	●
E.8	Unit E set temperature	○	○	○	●
E.9	Unit E capacity	○	○	○	●
E.10	Unit E set fan speed	○	○	○	●
E.11	Unit E actual suction overheating	○	○	○	●

Control board picture

WHP18M2A21S

Main control board

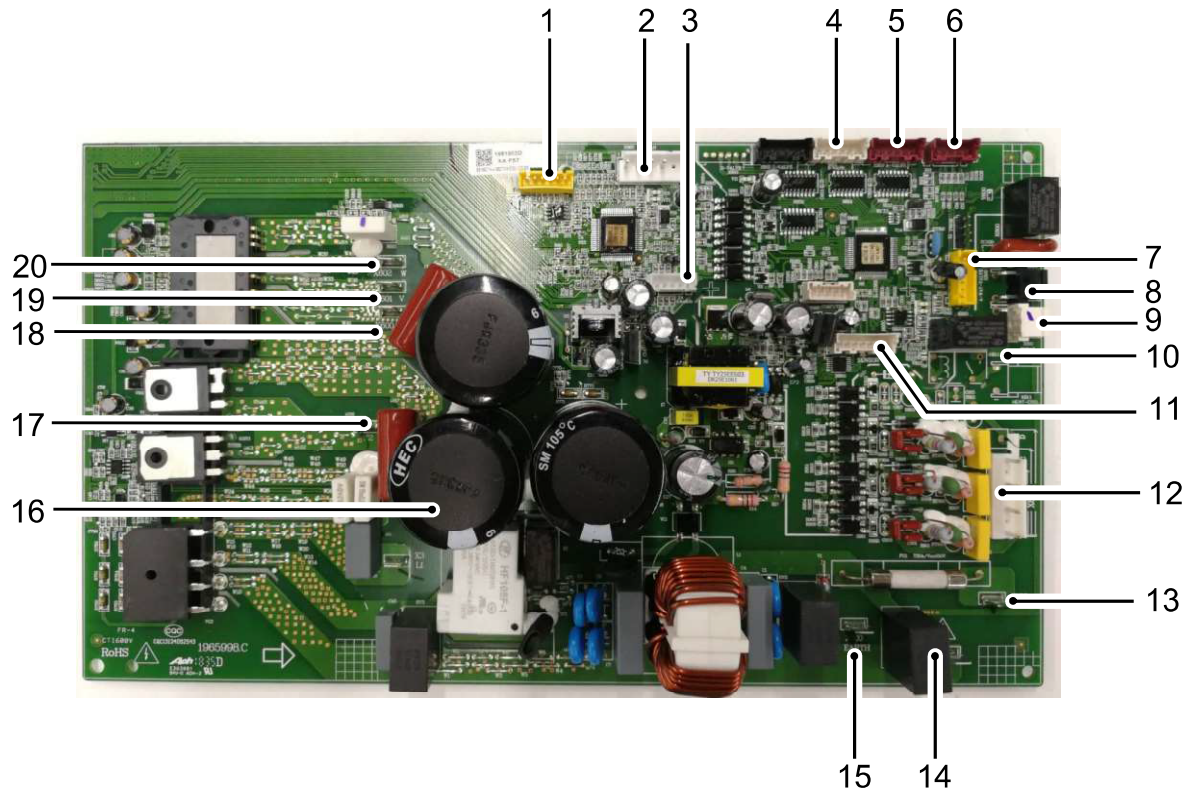

NO.	Description	NO.	Description
1	Driver EE Data Socket	11	Sensor Signal from Sensor Board
2	DC Motor	12	Communication Signal to Indoor
3	Only for developer	13	AC Power Lin
4	Electronic Expansion Valve B	14	AC Power Nin
5	Electronic Expansion Valve A	15	Earth
6	For developer	16	Reactor L1
7	Main EE data socket	17	Reactor L2
8	4-way Valve	18	Compressor U
9	Electric Heating Belt	19	Compressor V
10	Base Heater	20	Compressor W

WHP18M2A21S

Sensor board

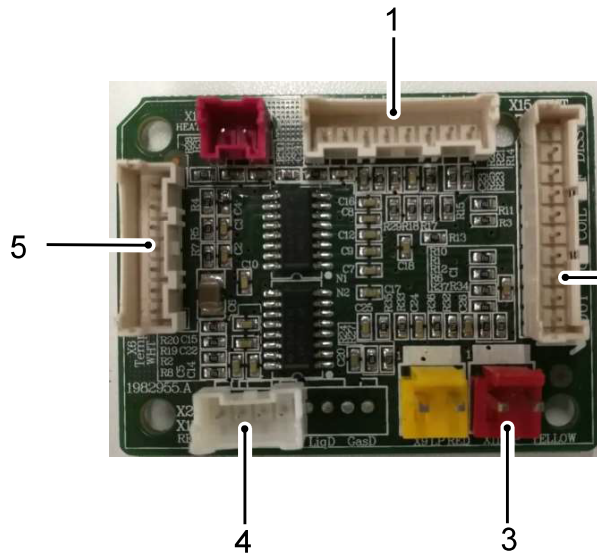

Maintenance board

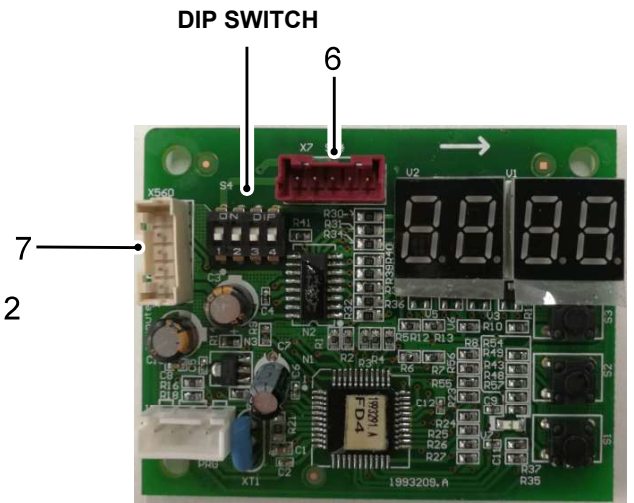

NO.	Description
1	Gas B/Liquid B/Gas A/Liquid A sensor
2	Discharge Sensor/ Defrost Sensor /Coil Sensor /Suction Sensor/ Outdoor Sensor
3	High Pressure Switch
4	Liquid C/ Gas C/Liquid D/Gas D sensor (Invalid for 18K)
5	Sensor Signal to Main Board
6	Select Switch Signal to Mainboard to Indoor
7	Communication signal to main board

WHP24M3A21S

Main control board

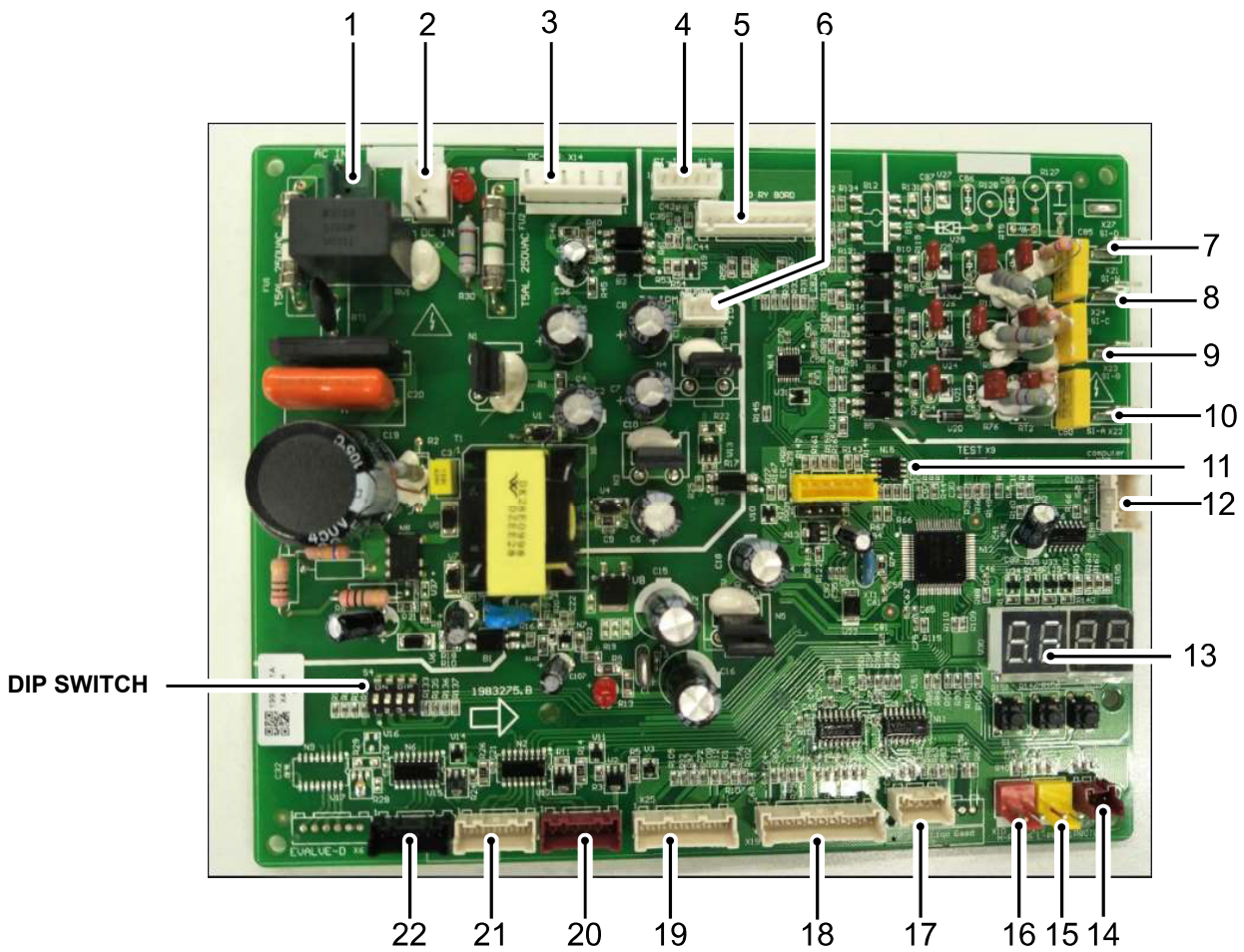

NO.	Description	NO.	Description
1	AC Power	12	Computer Monitor
2	DC Power	13	7-Segment display
3	DC fan	14	Compressor Overheat Protection Switch
4	IPM-SI	15	Low Pressure Switch
5	Signal to filter board	16	High Pressure Switch
6	15V & 5V Power	17	Liquid C/Gas C Sensor
7	SI-N	18	Discharge/defrost/Coil/Suction/Ambient Sensor
8	SI-C	19	Liquid A/Gas A/ Liquid B/Gas B Sensor
9	SI-B	20	Electronic Expansion Valve A
10	SI-A	21	Electronic Expansion Valve B
11	EE Program	22	Electronic Expansion Valve C

WHP24M3A21S

Drive board

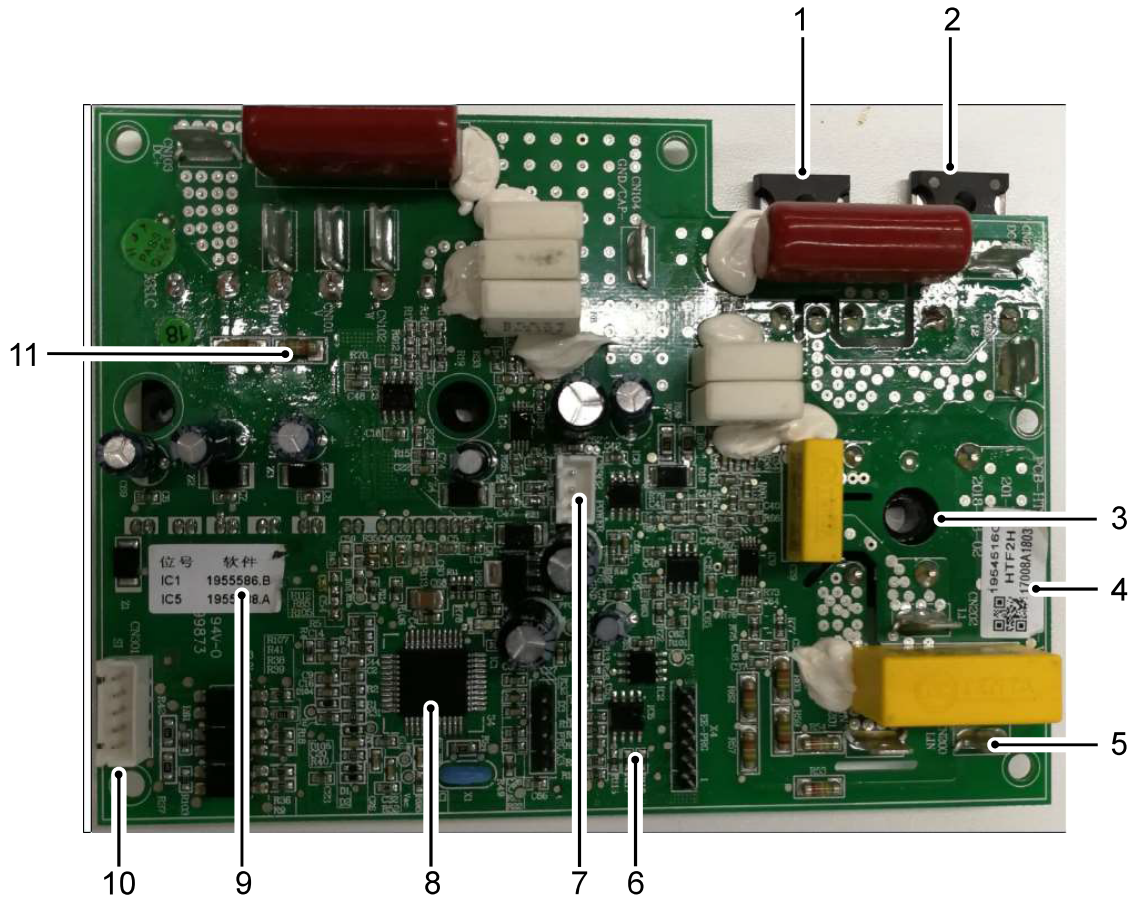

NO.	Description	NO.	Description
1	IGBT	7	15V & 5V Power
2	Diodes	8	MCU
3	Rectifier Bridge	9	CPU Code
4	Drive Board Code	10	Communication with Upper System
5	AC Power Input	11	IPM Module
6	EE		

WHP36M4A21S/WHP42M5A21S

Main control board

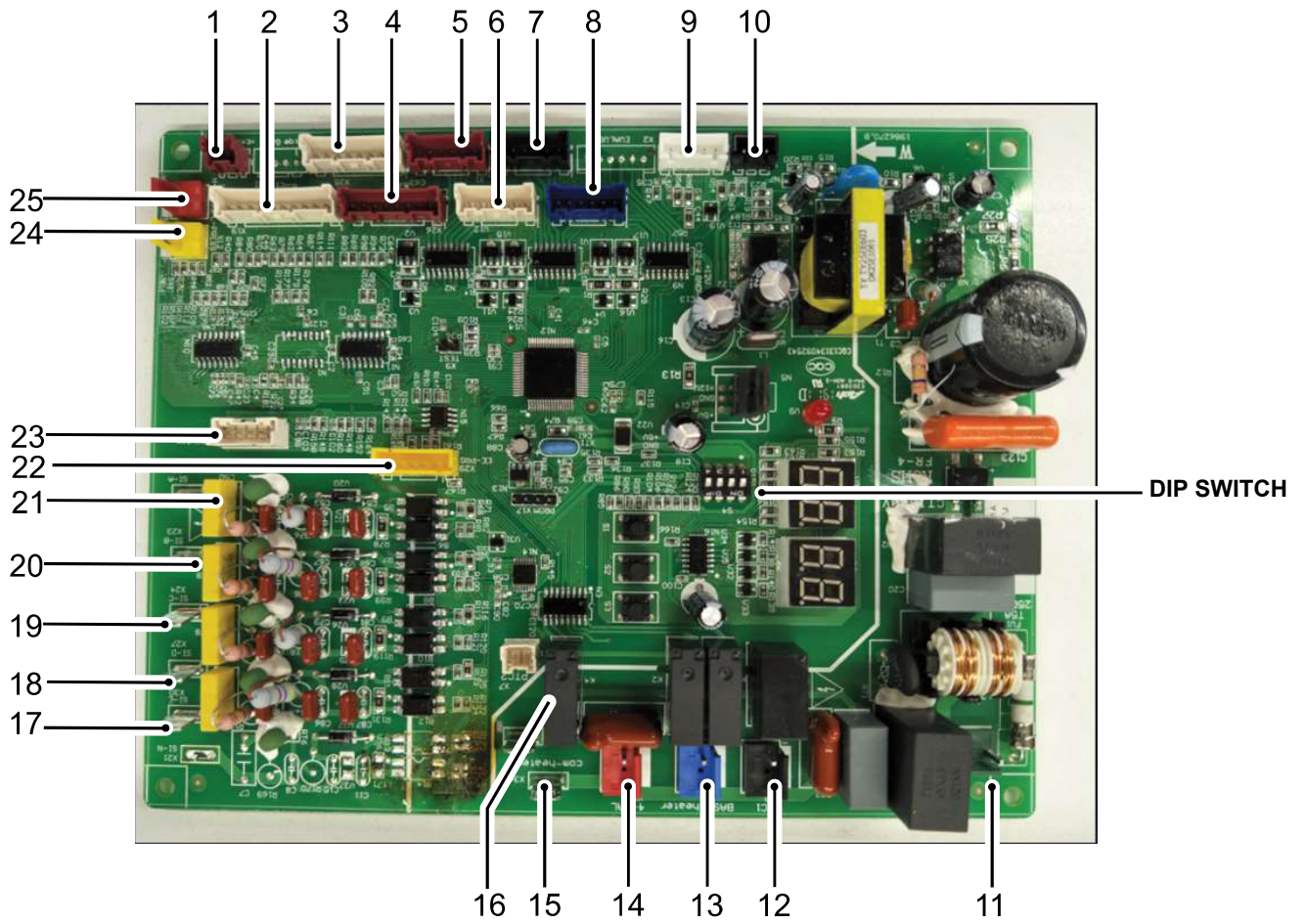

NO.	Description	NO.	Description
1	Compressor Overheat Protection Switch	14	4-Way Valve
2	Discharge/Defrost/ Coil/Suction/Ambient Sensor	15	Compressor Heater-N
3	Liquid A/Gas A/ Liquid B/Gas B Sensor	16	Compressor Heater-L
4	Liquid C/Gas C/ Liquid D/Gas D Sensor	17	SI-N
5	Electronic Expansion Valve A	18	SI-D
6	Electronic Expansion Valve B	19	SI-C
7	Electronic Expansion Valve C	20	SI-B
8	Electronic Expansion Valve D	21	SI-A
9	IPM-SI	22	EE
10	Driver	23	Checker/ Computer
11	AC In	24	Low Pressure Switch
12	AC Contactor	25	High Pressure Switch
13	Base Heater		

WHP36M4A21S/WHP42M5A21S

Drive board

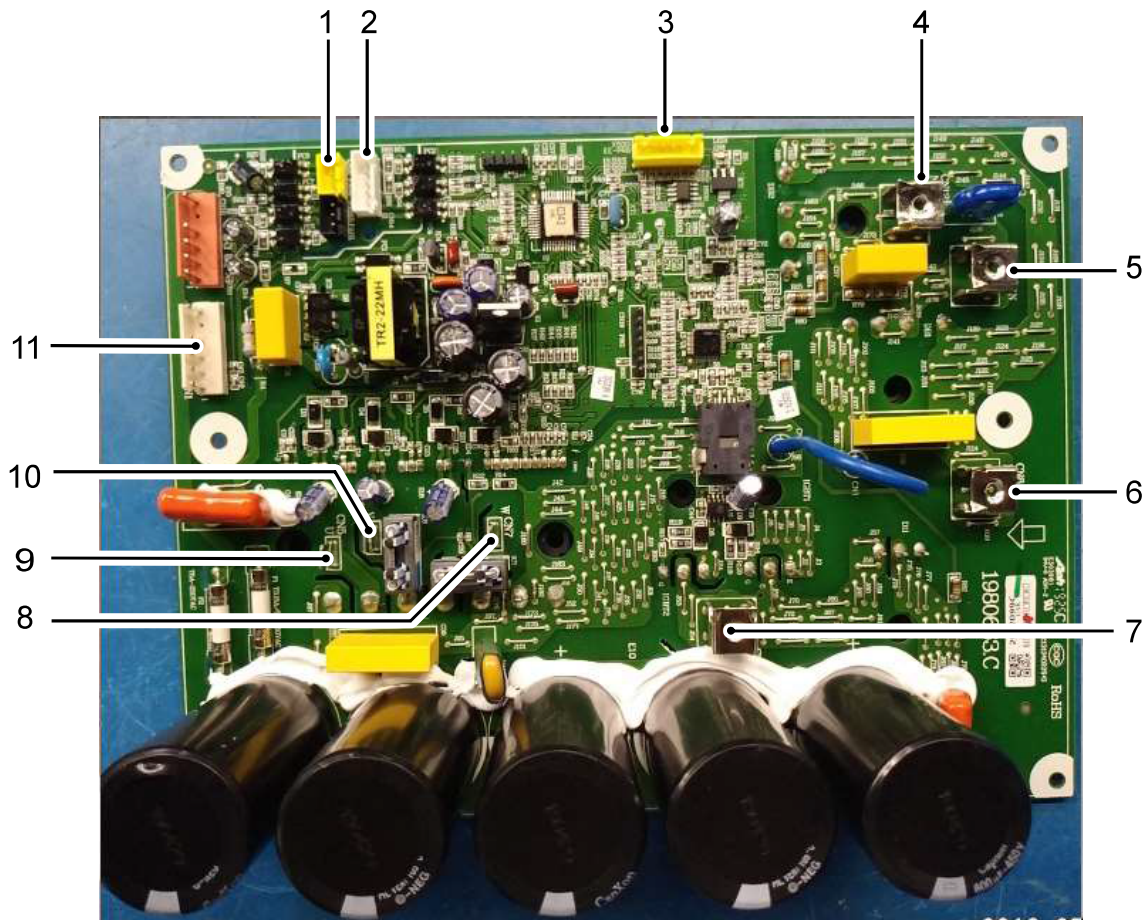

NO.	Description	NO.	Description
1	DC Fan Signal	7	Reactor L2
2	IPM-SI	8	Compressor W
3	EE	9	Compressor U
4	NIN	10	Compressor V
5	LIN	11	Driver
6	Reactor L1		

Control mode

1) Cooling Anti-freeze Protection

To prevent freezing caused by too low temperature of indoor evaporator, the air conditioner will implement real-time detection over the indoor coil temperature. If the indoor coil temperature is too low, the compressor will be prohibited from increasing the frequency or decrease the frequency even shut down automatically

2) Heating Overload Protection

To prevent system overload caused by excessive pressure in heating operation, the machine will implement real-time detection over the indoor fan-coil temperature:

If the indoor coil temperature grows higher, the compressor will be prohibited from increasing the frequency; If the temperature continues to rise, the compressor will decrease the frequency; If the indoor coil temperature is too high, the compressor will stop working immediately. The compressor then will reboot after the indoor coil temperature reduces.

3) Cooling Overload Protection

To prevent system overload due to excessive pressure during cooling operation, the machine will implement real-time detection over the outdoor condenser coil temperature: If the outdoor coil temperature grows higher, the compressor will be prohibited from increasing the frequency; If the temperature continues to rise, the compressor will decrease the frequency; If the outdoor fan-coil temperature is too high, then the compressor will stop working immediately. The compressor will reboot after the outdoor coil temperature reduces.

4) Discharge Temperature Protection

To prevent working conditions of compressor from deteriorating due to high discharge temperature, the machine will implement real-time detection over the discharge temperature.

If the discharge temperature grows higher, the compressor will be prohibited from increasing the frequency; if the temperature continues to rise, the compressor will decrease the frequency automatically; if the discharge temperature is too high, the compressor will stop working immediately. The compressor will then reboot when the discharge temperature returns to normal condition.

5) Oil-return Control

When the compressor continues to operate at low frequency, there will be an oil return. The compressor increases the frequency, and thus to return the oil in refrigerate system to the compressor.

6) Operation Mode

a. Mode Category

Air conditioning mode is the operation mode set by users through remote controller, four modes are available: cooling, heating, dehumidification, as well as fan mode.

b. Mode conflict

The operating mode of outdoor unit is decided by the operating mode of the indoor unit firstly booted. Indoor unit subsequently booted will firstly determine whether it's own mode is conflict with the outdoor mode. If so, the indoor unit will automatically shut down after three beeps; If there is no conflict, the indoor unit will boot normally. The relationship of mode conflict is as follows:

Driven choice / Active mode	Cooling	Dehumidification	Heating	fan
Cooling	√	√	×	√
Dehumidification	√	√	×	√
Heating	×	×	√	×
Fan	√	√	×	√

√———Mode conflict will not happen

×———Mode conflict will happen

7) Outdoor four-way Valve Control

Four-way valve of the outdoor machine shuts down when cooling but starts when heating. The operation of heating defrosting refers to defrosting operation and, when the heating remote shutdown, the four-way valve disconnects in 50s when the compressor stops working.

8) Start-up Protection

To prevent compressor from restart frequently in the condition that system pressure has not been completely balanced, it can't be restarted within 3 minutes.

9) Pressure Protection

Pressure switch is normally kept open. When the pressure grows too high, the pressure switch will close and soft will enter pressure protection control. soft will automatically decrease the frequency. If the pressure is still unable to return to normal condition after decreasing frequency, compressor will stop and report the fault code of pressure protection.

Troubleshooting

Trouble guide

Troubleshooting for normal malfunction

Troubleshooting	Possible Reason of Abnormality	How to Deal With
Air conditioner can not start up	<ol style="list-style-type: none"> 1. Power supply failure; 2. Trip of breaker or blow of fuse; 3. Power voltage is too low; 4. Improper setting of remote controller ; 5. Remote controller is short of power. 	<ol style="list-style-type: none"> 1. Check power supply circuit; 2. Measure insulation resistance to ground to see if there is any leakage; 3. Check if there is a defective contact or leak current in the power supply circuit; 4. Check and set remote controller again; 5. Change batteries.
The compressor starts or stops frequently	The air inlet and outlet has been blocked.	Remove block obstacles.
Poor cooling/heating	<ol style="list-style-type: none"> 1. The outdoor heat exchanger is dirty, such as condenser; 2. There are heating devices indoors; 3. The air tightness is not enough. People come in and out too frequently. 4. Block of outdoor heat exchanger; 5. Improper setting of temperature. 	<ol style="list-style-type: none"> 1. Clean the heat exchanger of the outdoor unit, such as condenser ; 2. Remove heating devices; 3. Keep certain air tightness indoors; 4. Remove block obstacles; 5. Check and try to set temperature again.
Sound from deforming parts	During system starting or stopping, a sound might be heard. However, this is due to thermal deformation of plastic parts.	It is not abnormal, and the sound will disappear soon.
Water leakage	<ol style="list-style-type: none"> 1. Drainage pipe blocked or broken; 2. Wrap of refrigerant pipe joint is not closed completely. 	<ol style="list-style-type: none"> 1. Change drainage pipe. 2. Re-wrap and make it tight.

When the air conditioner failure occurs, the fault code will display on control board.

HOW TO CHECK FAULT CODES

1) 18 model

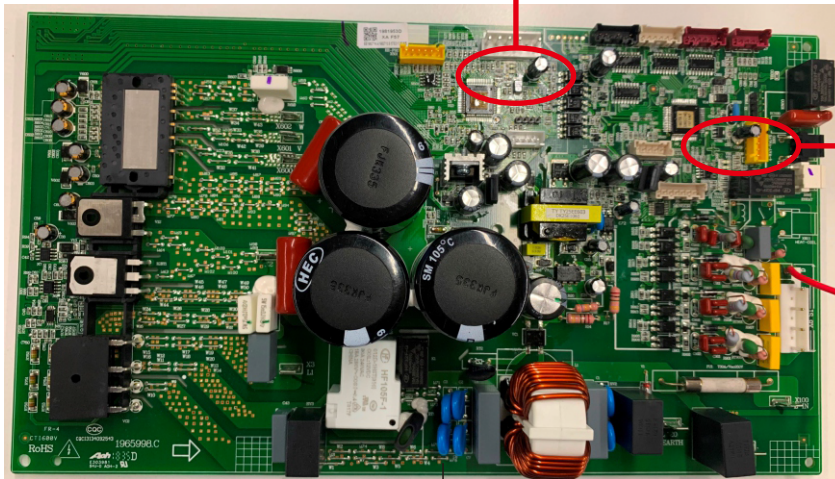

Main Control Board

2) 18/24/36/42 models

Main control failure

Fault code will display on 7 segment display on outdoor control board.

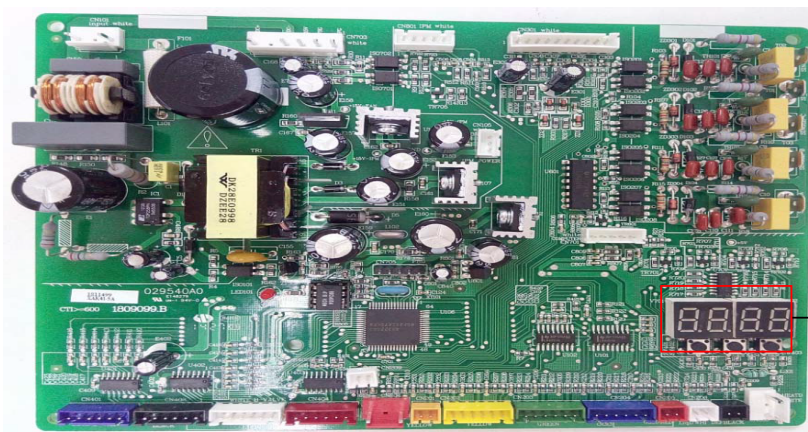

Outdoor Control Board

7 segment display

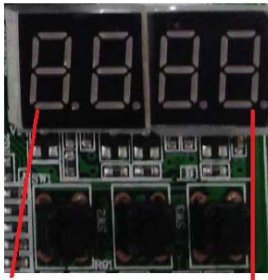

E shows failure occur

Display ERROR Code

Drive fault code display

The lamp of drive board flash shows failure occurs.
The drive failure lamp flicking times shows the failure code.

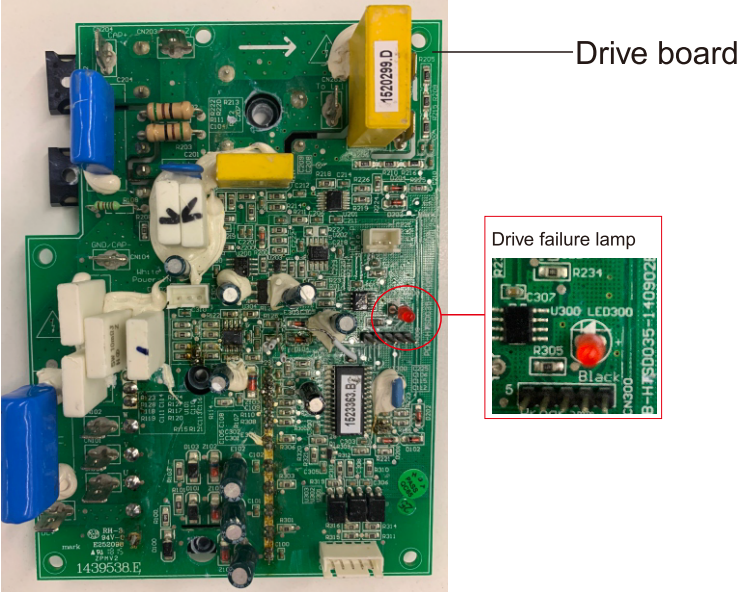

The drive failure lamp flicking times shows the failure code.

Fault codes

The following is the fault code table of outdoor units.

Outdoor fault code

Fault code	Fault description	Possible reasons for abnormality	How to deal with	Remarks
1	Outdoor ambient temperature sensor fault	<ol style="list-style-type: none"> 1.The outdoor ambient temperature sensor is connected loosely; 2.The outdoor ambient temperature sensor fails to work; 3.The sampling circuit fails. 	<ol style="list-style-type: none"> 1.Reconnect the outdoor ambient temperature sensor; 2.Replace the outdoor ambient temperature sensor components; 3.Replace the outdoor control board components. 	
2	Outdoor coil temperature sensor fault	<ol style="list-style-type: none"> 1.The outdoor coil temperature sensor is connected loosely; 2.The outdoor coil temperature sensor fails to work; 3.The sampling circuit fails. 	<ol style="list-style-type: none"> 1.Reconnect the outdoor coil temperature sensor; 2.Replace the outdoor coil temperature sensor components; 3.Replace the outdoor control board components. 	
3	The unit over-current turn off fault	<ol style="list-style-type: none"> 1. Control board current sampling circuit fails; 2. The current is over high because the supply voltage is too low; 3. The compressor is blocked; 4. Overload in cooling mode; 5. Overload in heating mode. 	<ol style="list-style-type: none"> 1. Replace the electrical control board components; 2. Normally protection 3. Replace the compressor 4. Please see the Note 3 5. Please see the Note 4 	
4	EEPROM Data error	<ol style="list-style-type: none"> 1.EE components fails; 2.EE components control circuit fails; 3.EE components are inserted incorrectly. 	<ol style="list-style-type: none"> 1.Replace the EE components; 2.Replace the outdoor control board components; 3.Reassembly the EE components. 	
5	Cooling freezing protection (the indoor coil temperature is too low) or heating overload (indoor coil temperature is too high)	<ol style="list-style-type: none"> 1.The indoor unit can not blow air normally; 2.The room temperature is too low in cooling mode or the room temperature is too high in heating; 3.The filter is dirty; 4.The duct resistance is too high to result in low air flow; 5.The setting fan speed is too low; 6.The indoor unit is not installed in accordance with the installation standards, and the air inlet is too close to the air outlet . 	<ol style="list-style-type: none"> 1.Check whether the indoor fan, indoor fan motor and evaporator work normally; 2.Normal protection; 3.Clean the filter; 4.Check the volume control valve, duct length etc.; 5.Set the speed with high speed; 6.Reinstall the indoor unit referring to the user manual to change the distance between the indoor unit and the wall or ceiling. 	
7	The communication fault between the indoor unit and outdoor unit	<ol style="list-style-type: none"> 1.The connection cable is connected improperly between the indoor unit and outdoor unit; 2.The communication cable is connected loosely; 3.The communication cable fails; 4.The indoor control board fails; 5.The outdoor control board fails; 6.Communication circuit fuse open; 7.The specification of communication cable is incorrect. 	<ol style="list-style-type: none"> 1.Reconnect the connection cable referring to the wiring diagram; 2.Reconnect the communication cable; 3.Replace the communication cable; 4.Replace the indoor control board; 5.Replace the outdoor control board; 6.Check the communication circuit, adjust the DIP switch and the short-circuit fuse. 7.Choose suitable communication cable referring to the user manual 	

Fault code	Fault description	Possible reasons for abnormality	How to deal with	Remarks
13	Compressor overheat protector device	<ol style="list-style-type: none"> 1. The wiring of the overload protector is connected loosely. 2. The overload protector fails . 3. The refrigerant is not enough; 4. The installation pipe is much longer than the normal one, but extra refrigerant is not added ; 5. The expansion valve fails; 6. The outdoor control board fails. 	<ol style="list-style-type: none"> 1. Reconnect the wiring of the overload protector; 2. Replace the overload protector; 3. Check the welding point of the unit to confirm whether it is leakage, and then recharge the refrigerant; 4. Add the refrigerant; 5. Replace expansion valve; 6. Replace the outdoor control board. 	
14	The high pressure switch operation or the unit is turned off for high pressure protection	<ol style="list-style-type: none"> 1.The wiring of the high pressure protector is connected loosely; 2.The high pressure protector fails; 3.The outdoor control board is abnormal; 4. Overload in cooling; 5. Overload in heating. 	<ol style="list-style-type: none"> 1. Reconnect the wiring of the high pressure protector; 2. Replace the high pressure protector; 3. Replace the outdoor control board; 4. Please refer to the Note 3; 5. Please refer to the Note 4. 	Applied to models with high pressure switch or pressure sensor
16	Overload protection in cooling mode	System overload	Please refer to the Note 3.	
17	Discharge temperature sensor fault	<ol style="list-style-type: none"> 1.The wiring of the discharge temperature sensor is connected loosely; 2.The discharge temperature sensor fails; 3.The sampling circuit is abnormal. 	<ol style="list-style-type: none"> 1. Reconnect the wiring of the discharge temperature sensor; 2. Replace the discharge temperature sensor fails; 3. The sampling circuit is abnormal. 	
18	AC voltage is abnormal	<ol style="list-style-type: none"> 1.The AC voltage>275V or <160V. 2.The AC voltage of sampling circuit on the driver board is abnormal. 	<ol style="list-style-type: none"> 1. Normal protection, please check the supply power; 2. Replace the driver board. 	
19	Suction temperature sensor fault	<ol style="list-style-type: none"> 1.The wiring of the suction temperature sensor is connected loosely; 2.The suction temperature sensor fails; 3.The sampling circuit is abnormal. 	<ol style="list-style-type: none"> 1.Reconnect the wiring of the suction temperature sensor; 2.Replace the suction temperature sensor; 3.Replace the outdoor control board. 	
22	The defrosting sensor fault	<ol style="list-style-type: none"> 1.The wiring of the defrosting sensor is connected loosely; 2.The defrosting sensor fails; 3.The sampling circuit is abnormal. 	<ol style="list-style-type: none"> 1. Reconnect the wiring of the defrosting sensor; 2. Replace the defrosting sensor; 3. Replace the outdoor control board. 	
23	Expansion valve A tube (thin) sensor fault	<ol style="list-style-type: none"> 1. The wiring of the sensor for the expansion valve A(thin tube) connect loose; 2. The sensor for the expansion A(thin tube) is failure; 3. The sampling circuit is abnormally 	<ol style="list-style-type: none"> 1. Reconnect the wiring of the sensor for the expansion valve A (thin tube); 2. Replace the sensor for the expansion valve A (thin tube); 3. Replace the outdoor control board. 	
24	Expansion valve B (thin)tube sensor fault	<ol style="list-style-type: none"> 1. The wiring of the sensor for the expansion valve B (thin tube) connect loose; 2.The sensor for the expansion valve B(thin tube) is failure; 3.The sampling circuit is abnormally 	<ol style="list-style-type: none"> 1. Reconnect the wiring of the sensor for the expansion valve B(thin tube); 2.Replace the sensor for the expansion valve B(thin tube); 3. Replace the outdoor control board. 	

Fault code	Fault description	Possible reasons for abnormality	How to deal with	Remarks
25	Expansion valve C (liquid) pipe sensor fault	<ol style="list-style-type: none"> 1. The wiring of the sensor for the expansion valve C (liquid pipe) is connected loosely; 2. The sensor of the expansion valve C (liquid pipe) fails; 3. The sampling circuit fails. 	<ol style="list-style-type: none"> 1. Reconnect the wiring of the sensor for the expansion valve C (liquid pipe). 2. Replace the sensor for the expansion valve C (liquid pipe); 3. Replace the outdoor control board. 	
26	Expansion valve D (liquid) pipe sensor fault	<ol style="list-style-type: none"> 1. The wiring of the sensor for the expansion valve D (liquid pipe) is connected loosely; 2. The sensor of the expansion valve D (liquid pipe) fails; 3. The sampling circuit fails. 	<ol style="list-style-type: none"> 1. Reconnect the wiring of the sensor for the expansion valve D (liquid pipe); 2. Replace the sensor for the expansion valve D (liquid pipe); 3. Replace the outdoor control board. 	
27	Expansion valve A (gas pipe) sensor fault	<ol style="list-style-type: none"> 1. The wiring of the sensor for the expansion valve A (gas pipe) is connected loosely; 2. The sensor of the expansion valve A (gas pipe) fails; 3. The sampling circuit fails. 	<ol style="list-style-type: none"> 1. Reconnect the wiring of the sensor for the expansion valve A (gas pipe); 2. Replace the sensor for the expansion valve A (gas pipe); 3. Replace the outdoor control board. 	
28	Expansion valve B (gas pipe) sensor fault	<ol style="list-style-type: none"> 1. The wiring of the sensor for the expansion valve B (gas pipe) connect is connected loosely; 2. The sensor of the expansion valve B (gas pipe) fails; 3. The sampling circuit fails. 	<ol style="list-style-type: none"> 1. Reconnect the wiring of the sensor for the expansion valve B (gas pipe); 2. Replace the sensor for the expansion valve B (gas pipe); 3. Replace the outdoor control board. 	
29	Expansion valve C (gas pipe) sensor fault	<ol style="list-style-type: none"> 1. The wiring of the sensor for the expansion valve B (gas pipe) connect is connected loosely; 2. The sensor of the expansion valve C (gas pipe) is fails; 3. The sampling circuit fails. 	<ol style="list-style-type: none"> 1. Reconnect the wiring of the sensor for the expansion valve B (gas pipe); 2. Replace the sensor for the expansion valve C (gas pipe); 3. Replace the outdoor control board. 	
30	Expansion valve D (gas pipe) sensor fault	<ol style="list-style-type: none"> 1. The wiring of the sensor for the expansion valve B (gas pipe) is connected loosely; 2. The sensor of the expansion valve D (gas pipe) fails; 3. The sampling circuit fails. 	<ol style="list-style-type: none"> 1. Reconnect the wiring of the sensor for the expansion valve B (gas pipe); 2. Replace the sensor for the expansion valve D (gas pipe); 3. Replace the outdoor control board. 	
45	IPM fault	<p>There are many reasons for this failure. You can check the driver board fault LED to further analyze the fault code of the drive board and to learn about what leads to the fault and how to operate it. Specific information can be seen in table 5, table 6.</p>	<p>See attached "analysis of the driving board fault".</p>	

Fault code	Fault description	Possible reasons for abnormality	How to deal with	Remarks
46	IPM and control board communication fault	<ol style="list-style-type: none"> 1.The cable between the control board and the driver board is connected loosely; 2.The cable between the control board and the driver board fails; 3.The driver board fails ; 4.The control board fails. 	<ol style="list-style-type: none"> 1.Reconnect the cable between the control board and the driver board; 2.Replace the communication cable between the control board and the driver board; 3.Replace the driver board; 4.Replace the control board. 	
47	Too high discharge temperature fault	<ol style="list-style-type: none"> 1. The refrigerant of the unit is not enough; 2.The refrigerant of the unit is not enough due to that the installation pipe is longer. 3.Throttling service fails; 4.The outdoor ambient temperature is too high. 	<ol style="list-style-type: none"> 1.Check the welding point to confirm whether the unit has leakage point, and then add some refrigerant. 2.Add some refrigerant referring to the installation user manual; 3.Replace the throttling service (such as capillary, expansion valve) 4.Normal protection. 	
48	The outdoor DC fan motor fault (upper fan motor)	<ol style="list-style-type: none"> 1.The connecting wiring of the up DC fan motor is loose; 2.The cord of the upper DC fan motor fails; 3.The upper DC fan motor fails; 4.The drive circuit of the upper DC fan motor fails; 5.The outdoor fan has been blocked. 	<ol style="list-style-type: none"> 1.Reconnect the wiring of the up DC fan motor; 2.Replace the upper DC fan motor; 3.Replace the upper DC fan motor; 4.Replace the driver board of the fan motor; 5.Check the outdoor fan and ensure the outdoor fan can run normally. 	
50	Expansion valve E (gas pipe) sensor fault	<ol style="list-style-type: none"> 1. The wiring of the sensor for the expansion valve E (gas pipe) is connected loosely; 2. The sensor of the expansion valve E (gas pipe) fails; 3. The sampling circuit fails. 	<ol style="list-style-type: none"> 1. Reconnect the wiring of the sensor for the expansion valve E (gas pipe); 2. Replace the sensor for the expansion valve E (gas pipe); 3. Replace the outdoor control board. 	
53	Expansion valve D (liquid) pipe sensor fault	<ol style="list-style-type: none"> 1.The wiring of the sensor for the expansion valve D (liquid pipe) is connected loosely; 2.The sensor of the expansion valve D (liquid pipe) fails; 3.The sampling circuit fails. 	<ol style="list-style-type: none"> 1. Reconnect the wiring of the sensor for the expansion valve D (liquid pipe); 2. Replace the sensor for the expansion valve D (liquid pipe); 3. Replace the outdoor control board. 	
96	Lacking of refrigerant	The refrigerant of the unit is not enough.	Discharge the refrigerant and charge the refrigerant referring to the rating label.	
97	4-way valve commutation failure fault	<ol style="list-style-type: none"> 1.The connecting wiring of the 4-way valve coil is loose; 2.The 4-way valve coil fails; 3.The 4-way valve fails; 4.The driver board of the 4-way valve fails. 	<ol style="list-style-type: none"> 1. Reconnect the wiring of the 4-way valve; 2. Replace the 4-way valve coil; 3. Replace the 4-way valve; 4.Replace the driver board of the 4-way valve. 	

Fault code	Fault description	Possible reasons for abnormality	How to deal with	Remarks
74	Indoor EEPROM Data 2 fault	EE in MCU is fails, the unit can run, but the function user has set is ineffective.	Replace EE data in MCU.	
81	Indoor ambient Temperature Sensor Fault	<ol style="list-style-type: none"> 1. The cable of the room temperature sensor is connect loosely; 2. The room temperature sensor fails; 3. The sampling circuit is abnormal. 	<ol style="list-style-type: none"> 1. Reconnect the cable of the room temperature sensor; 2. Replace the room temperature sensor; 3. Replace the indoor control board. 	
83	Evaporator Middle Temperature Sensor Fault	<ol style="list-style-type: none"> 1.The cable of the coil temperature sensor of the evaporator fails; 2.The coil temperature sensor of the evaporator fails; 3.The sampling circuit is abnormal. 	<ol style="list-style-type: none"> 1. Reconnect the cable of the coil temperature sensor of the evaporator; 2. Replace the coil temperature sensor of the evaporator; 3. Replace the indoor control board. 	
FE (254)	Communication between main control board & Wired controller Fault (display on wired controller)	<ol style="list-style-type: none"> 1. The wired controller and the indoor control board are connected loosely. 2. The sequence of the wiring between the wired controller to the indoor control board is wrong; 3. The wiring between the wired controller to the indoor control board fails; 4. The wired controller is fails; 5. The indoor control board is abnormal. 	<ol style="list-style-type: none"> 1.Reconnect the wiring between the wired controller to the indoor control board; 2. Replace the wiring between the wired controller to the indoor control board; 3. Replace the wiring between the wired controller to the indoor control board; 4. Replace the wired controller; 5. Replace the indoor control Board. 	
ER	Communication between main control board & display board Fault (displays on display board)	<ol style="list-style-type: none"> 1.The wiring between the display board to the indoor control board is connected loosely; 2.The sequence of the wiring between the display board to the indoor control board is wrong; 3.The wiring between the display board to the indoor control board fails; 4.The display board fails; 5.The indoor control board fails. 	<ol style="list-style-type: none"> 1. Reconnect the wiring between the display board to the indoor control board; 2. Replace the wiring between the display board to the indoor control board; 3. Replace the wiring between the display board to the indoor control board; 4. Replace the display board; 5. Replace the indoor control board. 	

The following is the fault code table of indoor unit.

Table 2 Indoor fault code

Fault code	Fault description	Possible reasons for abnormality	How to deal with	Remarks
51	Drainage protection	<ol style="list-style-type: none"> 1. The water level of the drain pan exceed safe level; 2. The cable of the water level switch is connected loosely; 3. The water level switch fails; 4. The control board fails. 	<ol style="list-style-type: none"> 1.1 Check whether there is something blocking the drain hose or the height of the drain hose is too high; 1.2 Check the water pump and replace the water pump if the water pump fails; 2. Reconnect the cable of the water level switch referring to the wiring diagram; 3. Replace the water level switch; 4. Replace the control board. 	
55	Mode conflict fault	The user set the conflicting mode for more than two indoor units.	Reset the operation mode for the indoor unit, for with one outdoor unit, the user should avoid setting the conflicting operation mode with the indoor units.	
64	Communication between Indoor & Outdoor unit Fault	<ol style="list-style-type: none"> 1. The indoor unit and the outdoor unit are not connected properly; 2. The communication cable is connected loosely; 3. The communication cable between the indoor unit and the outdoor unit is failure or the cable between the indoor control board to terminal fails or the cable between the outdoor control board to the terminal fails; 4. The indoor control board fails; 5. The outdoor control board fails. 	<ol style="list-style-type: none"> 1. Reconnect the connection cable referring to the indoor and outdoor wiring diagram; 2. Reconnect the communication cable referring to the indoor and outdoor wiring diagram; 3. Replace the communication cable referring to the indoor and outdoor wiring diagram; 4. Replace the indoor control board; 5. Replace the outdoor control board. 	
71	Indoor unit zero check fault	<ol style="list-style-type: none"> 1. The motor wire is loosen; 2. The motor connection is open; 3. The motor fails; 4. Control board fails. 5. Indoor fan is baffled. 	<ol style="list-style-type: none"> 1. Replace the motor wire and make sure the wire connect is well; 2. Replace the motor wire; 3. Change the motor; 4. Change the indoor control board; 5. Check and elimination of fan motor rotation. 	
72	Indoor fan motor fault	<ol style="list-style-type: none"> 1. The cable of the indoor fan motor is connected loosely; 2. The cable of the indoor fan motor fails; 3. The indoor fan motor fails; 4. The indoor control board fails. 	<ol style="list-style-type: none"> 1. Reconnect the cable of the fan motor; 2. Replace the cable of the fan motor; 3. Replace the fan motor; 4. Replace the indoor control board; 5. Check the indoor fan and ensure the indoor fan can run normally. 	
73	Indoor EEPROM Data 1 fault	<ol style="list-style-type: none"> 1. Indoor EE components fails; 2. The control circuit of the EE components fails; 3. The EE components has been inserted in opposite direction. 	<ol style="list-style-type: none"> 1. Replace the EE components; 2. Replace the indoor control board; 3. Reassembly the EE components of the indoor control board. 	

Fault code	Fault description	Possible reasons for abnormality	How to deal with	Remarks
74	Indoor EEPROM Data 2 fault	EE in MCU fails, the unit can run, but the function user has set is ineffective.	Replace EE data in MCU.	
81	Indoor ambient Temperature Sensor Fault	<ol style="list-style-type: none"> 1. The cable of the room temperature sensor is connected loosely; 2. The room temperature sensor fails; 3. The sampling circuit is abnormal. 	<ol style="list-style-type: none"> 1. Reconnect the cable of the room temperature sensor; 2. Replace the room temperature sensor; 3. Replace the indoor control board. 	
83	Evaporator Middle Temperature Sensor Fault	<ol style="list-style-type: none"> 1. The cable of the coil temperature sensor of the evaporator fails; 2. The coil temperature sensor of the evaporator fails; 3. The sampling circuit is abnormal. 	<ol style="list-style-type: none"> 1. Reconnect the cable of the coil temperature sensor of the evaporator; 2. Replace the coil temperature sensor of the evaporator; 3. Replace the indoor control board. 	
FE (254)	Communication between main control board & Wired controller Fault (display on wired controller)	<ol style="list-style-type: none"> 1. The wired controller and the indoor control board are connected loosely. 2. The sequence of the wiring between the wired controller to the indoor control board is wrong; 3. The wiring between the wired controller to the indoor control board fails; 4. The wired controller is fails; 5. The indoor control board is abnormal. 	<ol style="list-style-type: none"> 1. Reconnect the wiring between the wired controller to the indoor control board; 2. Replace the wiring between the wired controller to the indoor control board; 3. Replace the wiring between the wired controller to the indoor control board; 4. Replace the wired controller; 5. Replace the indoor control board. 	
ER	Communication between main control board & display board Fault (displays on display board)	<ol style="list-style-type: none"> 1. The wiring between the display board to the indoor control board is connected loosely; 2. The sequence of the wiring between the display board to the indoor control board is wrong; 3. The wiring between the display board to the indoor control board fails; 4. The display board fails; 5. The indoor control board fails. 	<ol style="list-style-type: none"> 1. Reconnect the wiring between the display board to the indoor control board; 2. Replace the wiring between the display board to the indoor control board; 3. Replace the wiring between the display board to the indoor control board; 4. Replace the display board; 5. Replace the indoor control board. 	

NOTE 1:

If the indoor unit can not start or the indoor unit stops itself after 30s, at the same time the unit do not display the fault code, please check the fire and the socket of the control board.

NOTE 2:

If the indoor unit displays the 75,76,77,78 fault code after you turn on the unit, please check the TEST seat of the indoor control board or the TEST detection circuit to see whether short circuit occurs.

NOTE 3: Overload in cooling mode

Overload in cooling mode		
sr.	The root cause	Corrective measure
1	The refrigerant is excessive.	Discharge the refrigerant, and recharge the refrigerant referring to the rating label.
2	The outdoor ambient temperature is too high.	Please use within allowable temperature range
3	Short-circuit occurs in the air outlet and air inlet of the outdoor unit.	Adjust the installation of the outdoor unit referring to the user manual.
4	The outdoor heat exchanger is dirty, such as condenser.	Clean the heat exchanger of the outdoor unit, such as condenser.
5	The speed of the outdoor fan motor is too low.	Check the outdoor fan motor and fan capacitor.
6	The outdoor fan is broken or the outdoor fan is blocked.	Check the outdoor fan.
7	The air inlet and outlet has been blocked.	Remove the blocked objects.
8	The expansion valve or the capillary fails.	Replace the expansion valve or the capillary.

NOTE 4: Over load in heating mode

Overload in heating mode		
sr.	The root cause	Corrective measure
1	The refrigerant is excessive.	Discharge the refrigerant, and recharge the refrigerant referring to the rating label.
2	The indoor ambient temperature is too high.	Please use within allowable temperature range.
3	Short-circuit occurs in the air outlet and air inlet of the indoor unit.	Adjust the installation of the indoor unit referring to the user manual.
4	The indoor filter is dirty.	Clean the indoor filter.
5	The speed of the indoor fan motor is too low.	Check the indoor fan motor and fan capacitor.
6	The indoor fan is broken or the outdoor fan is blocked.	Check the indoor fan.
7	The air inlet and outlet has been blocked.	Remove the blocked objects.
8	The expansion valve or the capillary fails.	Replace the expansion valve or the capillary.

Drive fault code (18 model)

Fault code	Fault description	Possible reasons for abnormality	How to deal with
1	Inverter DC voltage overload fault	1. Power supply input is too high or too low; 2. Driver board fault.	1. Check power supply 2. Change driver board.
2	Inverter DC low voltage fault		
3	Inverter AC current overload fault		
4	Out-of-step detection	1. Compressor phase lost ; 2. Bad driver board components ; 3. The compressor insulation fault	1. Check compressor wire connection; 2. Change driver board ; 3. Change compressor.
5	Loss phase detection fault (speed pulsation)		
6	Loss phase detection fault (current imbalance)		
7	Inverter IPM fault (edge)	1. System overload or current overload; 2. Driver board fault. 3. Compressor oil shortage, serious wear of crankshaft ; 4. The compressor insulation fault.	1. Check the system. 2. Change driver board; 3. Change the compressor; 4. Change the compressor.
8	Inverter IPM fault (level)		
9	PFC_IPM IPM fault (edge)		
10	PFC_IPM IPM fault (level)		
11	PFC power detection of failure	1. The power supply is not stable; 2. Instantaneous power off; 3. Driver board failure.	1. Check the power supply. 2. No need to deal with. 3. Change the driver board.
12	PFC overload current detection of failure.	1. System overload, current is too high; 2. Driver board fails; 3. PFC fails.	1. Check the system; 2. Change the driver board; 3. Change the PFC.
13	DC voltage detected abnormal .	1. Input voltage is too high or too low; 2. Driver board fails.	1. Check the power supply. 2. Change the driver board.
14	PFC LOW voltage detected failure.		
15	AD offset abnormal detected failure.	Driver board fails.	Change the driver board.
16	Inverter PWM logic set fault.		
17	Inverter PWM initialization failure		
18	PFC_PWM logic set fault.		
19	PFC_PWM initialization fault.		
20	Temperature abnormal.		
21	Shunt resistance unbalance adjustment fault		
22	Communication failure.	1. Communication wire connection is not proper. 2. Driver board fails. 3. Control board fails.	1. Check the wiring. 2. Change the driver board. 3. Change the control board.
23	Motor parameters setting of failure	Initialization abnormal.	Reset the power supply.
25	EE data abnormal	Driver board EEPROM abnormal	1. Change EEPROM ; 2. Change driver board.
26	DC voltage mutation error	1. Power input changes suddenly 2. Driver board fails.	1. Check power supply, to provide stable power supply; 2. Change driver board.
27	D axis current control error	1. System overload, phase current is too high; 2. Driver board fails.	1. Check system if normally. 2. Check stop valve if is open; 3. Change driver board.
28	Q axis current control error	1. System overload, phase current is too high ; 2. Driver board fails.	1. Check system if normally. 2. Check stop valve if is open; 3. Change driver board.
29	Saturation error of d axis current control integral	1. System overload suddenly; 2. Compressor parameter is not suitable; 3. Driver board fails.	1. Check system if normally. 2. Check stop valve if is open; 3. Change driver board.
30	Saturation error of q axis current control integral	1. System overload suddenly; 2. Compressor parameter is not suitable; 3. Driver board fails.	1. Check system if normally. 2. Check stop valve if is open; 3. Change driver board.

DriveFault Code (24/36/42 models)

Fault code	Fault description	Possible reasons for abnormality	How to deal with
1	Q axis current detection, failure in drive control	1. Compressor wire is not connected properly; 2. Bad driver board components; 3. Compressor start load is too large; 4. Compressor demagnetization; 5. Compress or oil shortage serious wear of crankshaft; 6. The compressor insulation fails.	1. Check compressor wire; 2. Change driver board ; 3. Turn on the machine after the pressure is balanced again; 4. Change Compressor; 5. Change the Compressor; 6. Change the Compressor.
2	Phase current detection, failure in drive control	1.Compressor voltage default phase; 2.Bad driver board components; 3.The compressor insulation fault.	1.Check compressor wire connection; 2.Change the driver board; 3. Change the Compressor.
3	Initialization, phase current imbalance	Bad driver board components.	Change driver board .
4	Speed estimation, failure in drive control	1.Bad driver board components; 2.Compressor shaft clamping; 3.The compressor insulation fails.	1.Change driver board ; 2.Change the Compressor ; 3.Change the Compressor .
5	IPM FO output fault	1. System overload or current overload. 2. Driver board fails; 3. Compressor oil shortage,serious wear of crankshaft; 4. The compressor insulation fault.	1.Check the air-conditioner system; 2.Change the driver board; 3.Change the Compressor; 4. Change the Compressor.
6	Communication between driver board and control board fault	1.Communication wire connect not well; 2. Driver board fault; 3. Control board fault;	1. Check compressor wire connect. 2. Change the driver board; 3. Change the control board ;
7	AC voltage,overload voltage	1. Supply voltage input is too high or too low; 2. Driver board fails;	1.Check power supply; 2.Change the driver board;
8	DC voltage,overload voltage	1. Supply voltage input is too high ; 2. Driver board fault;	1. Check power supply; 2. Change the driver board;
9	AC voltage imbalance	Driver board fails;	Change the driver board;
10	The PFC current detection circuit fault before compressor is ON	Bad driver board components;	Change the driver board
11	AC voltage supply in outrange	1.Power supply abnormal, power frequency out of range; 2.Driver board fails;	1. Check the system; 2. Change the driver board;
12	Products of single-phase PFC over-current, FO output low level	1. System overload, current is too large; 2. Driver board fault; 3. PFC fault.	1. Check the system; 2. Change the driver board; 3. Change PFC.
	Inverter over current (3-phase power supply air conditioners)	1. System overload, current is too large; 2. Driver board fault; 3. Compressor oil shortage, serious wear of crankshaft; 4. The compressor insulation fault.	1. Check the system; 2. Change the driver board; 3. Change the Compressor; 4. Change the Compressor.
13	Inverter over current	1. System overload, current is too large; 2. Driver board fault; 3. Compressor oil shortage,serious wear of crankshaft; 4. The compressor insulation fault.	1. Check the system; 2. Change the driver board; 3. Change the Compressor; 4. Change the Compressor.
14	PFC over current(single-phase air-conditioner)	1. System overload, current is too large; 2. Driver board fault; 3. PFC fault.	1. Check the system; 2. Change the driver board; 3. Change PFC.
	Phase imbalance or phase lacks or the instantaneous power failure (only for 3-phase power supply air conditioners)	1.3-Phase voltage imbalance; 2.The 3-phase power supply phase lost; 3. Power supply wiring wrong; 4. Driver board fault.	1, Check the power supply; 2. Check the power supply; 3. Check the power supply wiring connect; 4. Change the driver board.
15	The instantaneous power off detection	1.The power supply is not stable ; 2.The instantaneous power failure ; 3.Driver board fault;	1. Check the power supply; 2. Not fault; 3. Change the driver board.

Fault code	Fault description	Possible reasons for abnormality	How to deal with
16	Low DC voltage 200V	1. Voltage input is too low; 2. Drive board fault.	1. Check the power supply. 2. Change the driver board.
18	Driver board read EE data error	1. EEPROM has no data or data error; 2. EEPROM circuit fault.	1. Change EEPROM component; 2. Change the driver board.
19	PFC chip receive data fault	Abnormal communication loop.	Change the drive board.
20	PFC soft start abnormal	Abnormal PFC drive loop.	Change the drive board.
21	The compressor drive chip could not receive data from PFC chip.	Communication loop fault.	Change the drive board.

Parts

INDOOR UNIT
WHP07WMA21S
WHP09WMA21S

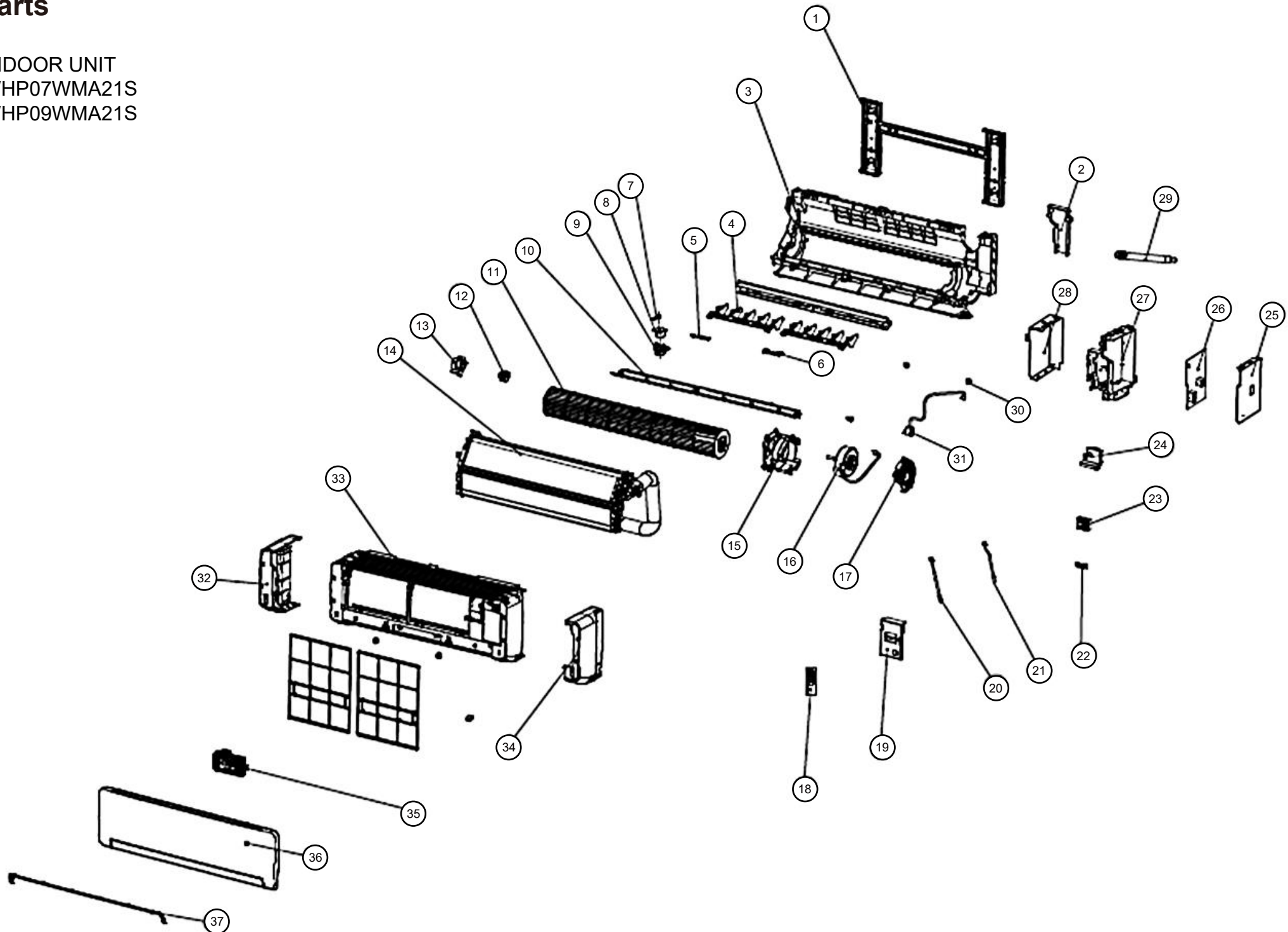

INDOOR UNIT
WHP07WMA21S
WHP09WMA21S

No.	Part number	Description
1	1906600	Bracket wall
2	1984201	Baffle
3	1854439	Base assembly
4	1555378	Vertical louver
5	1555381	Holder center
6	1555385	Holder center
7	1555387	Holder center
8	1260259	Step motor
9	1555386	Guard motor
10	1555374	Louver
11	1466014	Cross flow fan assy
12	1223739	Bearing
13	1465670	Baffle
14	1512275	Evaporator
15	2091423	Guard motor
16	1838324	DC motor
17	2091436	Cover motor
18	4151687	Remote control
19	1840039	Cover wire
20	1837499	Thermistor pipe
21	1896665	Thermistor pipe
22	1839902	Clamp cord
23	1852126	Terminal
24	1465763	Cover wire
25	1465762	Electric box cover
26	1994823	Controller PCB
27	1868909	Electric box
28	1465761	Electric box cover
29	1470426	Drain hose
30	1222824	Plug
31	1468408	Step motor
32	1555390	Ornamental part
33	2007198	Front panel
34	1555391	Ornamental part
35	1874771	Display assembly
36	4151756	Intake grille
37	1826563	Ornamental part
	1506312	Air filter

INDOOR UNIT
WHP12WMA21S

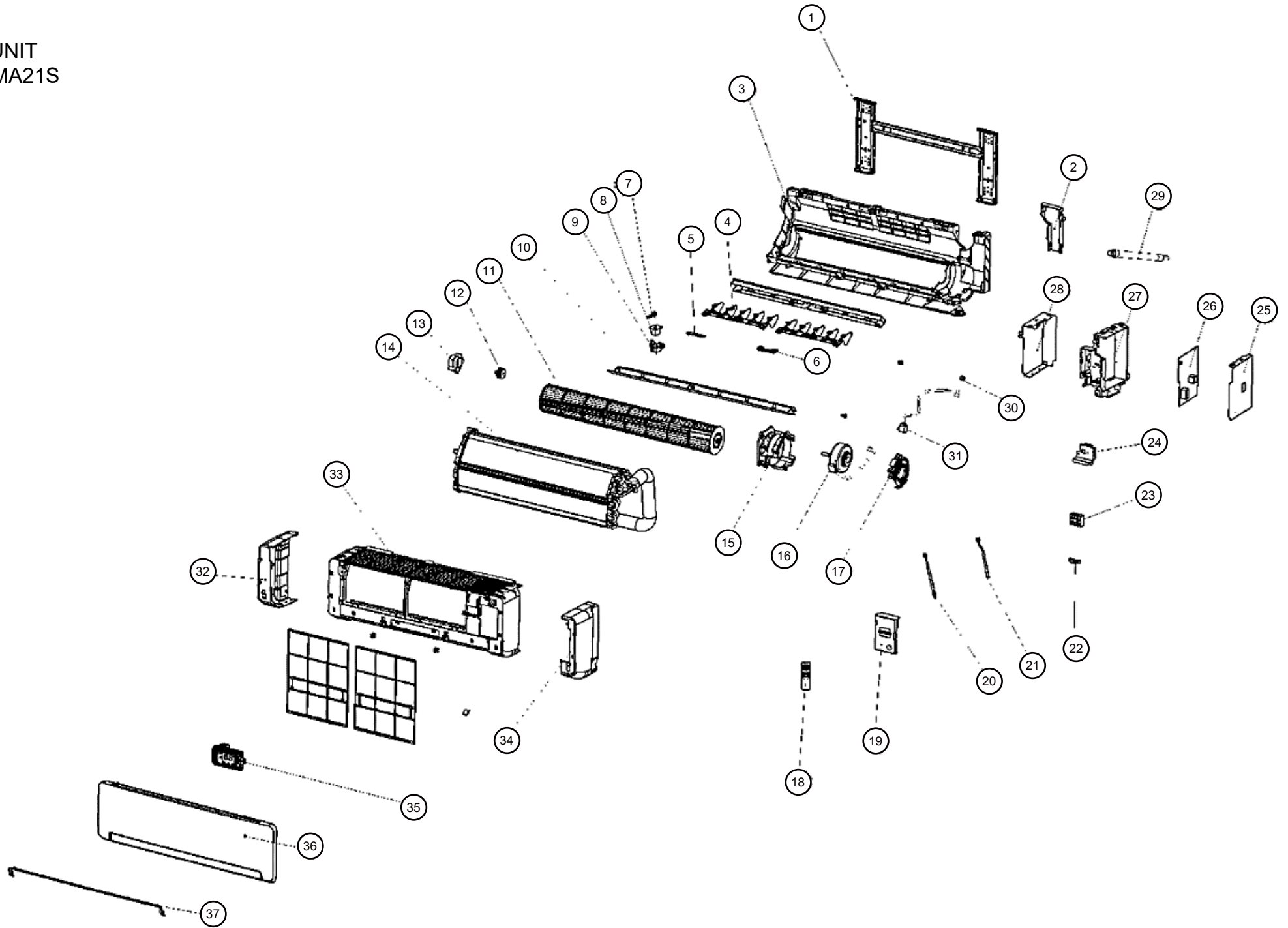

INDOOR UNIT
WHP12WMA21S

No.	Part number	Description
1	1906600	Bracket wall
2	1984201	Baffle
3	1854439	Base assembly
4	1555378	Vertical louver
5	1555381	Holder center
6	1555385	Holder center
7	1555387	Holder center
8	1260259	Step motor
9	1555386	Guard motor
10	1555374	Louver
11	1466014	Cross flow fan assy
12	1223739	Bearing
13	1465670	Baffle
14	1512275	Evaporator
15	2091423	Guard motor
16	1838324	DC motor
17	2091436	Cover motor
18	4175260	Remote control
19	1840039	Cover wire
20	1837499	Thermistor pipe
21	1896665	Thermistor pipe
22	1839902	Clamp cord
23	1852126	Terminal
24	1465763	Cover wire
25	1465762	Electric box cover
26	1994827	Controller PCB
27	1868909	Electric box
28	1465761	Electric box cover
29	1470426	Drain hose
30	1222824	Plug
31	1468408	Step motor
32	1555390	Ornamental part
33	2007198	Front panel
34	1555391	Ornamental part
35	1874771	Display assembly
36	4151756	Intake grille
37	1826563	Ornamental part
	1506312	Air filter

INDOOR UNIT
WHP18WMA21S

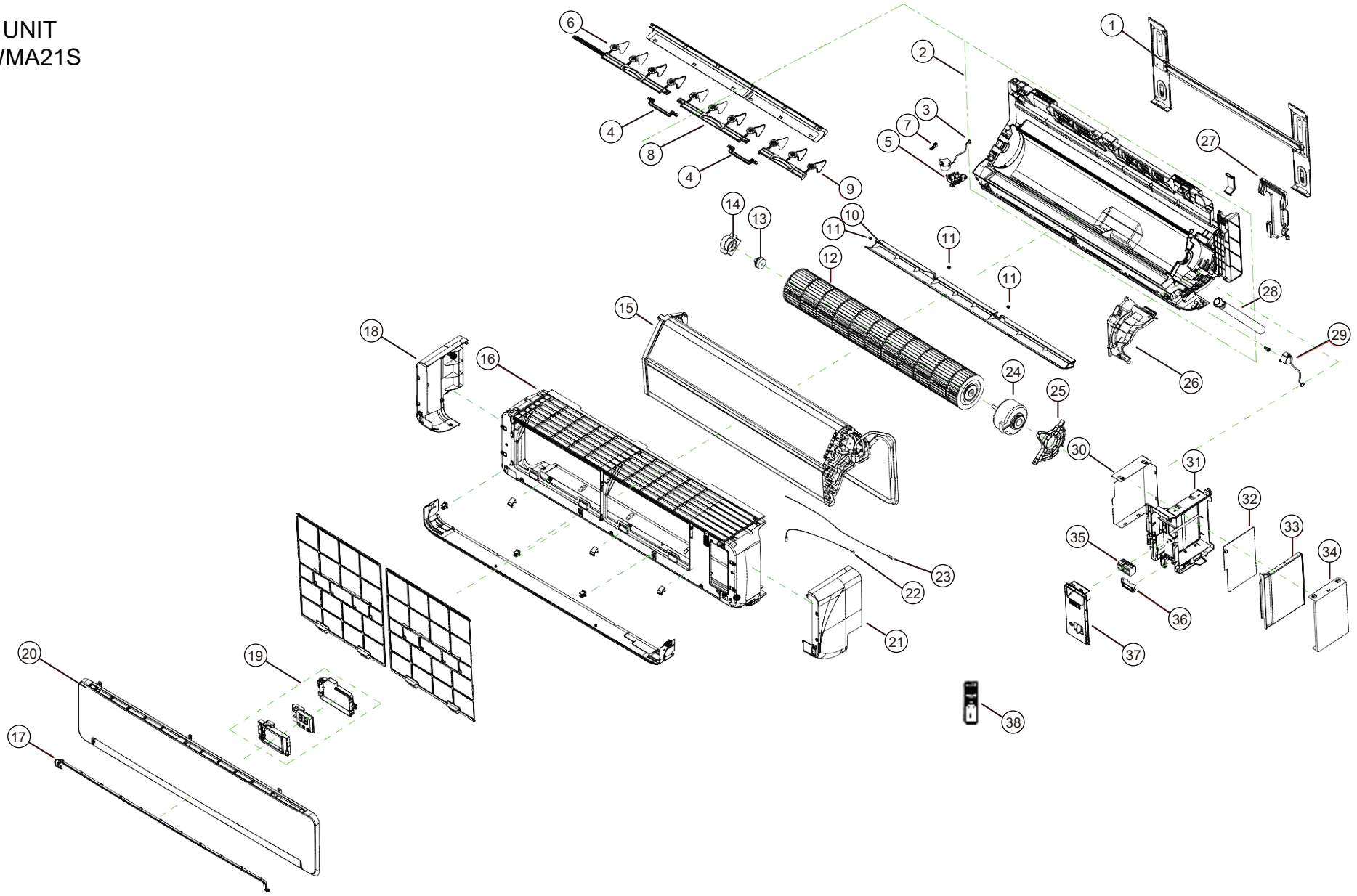

INDOOR UNIT
WHP18WMA21S

No.	Part number	Description
1	1907022	Bracket wall
2	1954365	Base assembly
3	1260311	Step motor
4	1541366	Holder center
5	1541373	Guard motor
6	1541456	Vertical louver
7	1541368	Holder center
8	1550291	Vertical louver
9	1550300	Vertical louver
10	1541363	Louver
11	1222824	Plug
12	1541633	Cross flow fan assy
13	1223738	Bearing
14	1465670	Baffle
15	1838915	Evaporator
16	1541382	Front panel
17	1826559	Ornamental part
18	1541388	Ornamental part
19	1824935	Display assembly
20	4151757	Intake grille
21	1541389	Ornamental part
22	1837499	Thermistor pipe
23	1896665	Thermistor pipe
24	1561456	Motor fan
25	1541374	Cover motor
26	1541375	Guard motor
27	1541361	Baffle
28	1470426	Drain hose
29	1819726	Step motor
30	1541500	Electric box cover
31	1870720	Electric box
32	1989042	Controller PCB
33	1541507	Cover wire
34	1837043	Cover wire
35	1852126	Terminal
36	1840141	Clamp cord
37	1541379	Cover display
38	4175260	Remote control
	1541387	Air filter

INDOOR UNIT
WHP24WMA21S

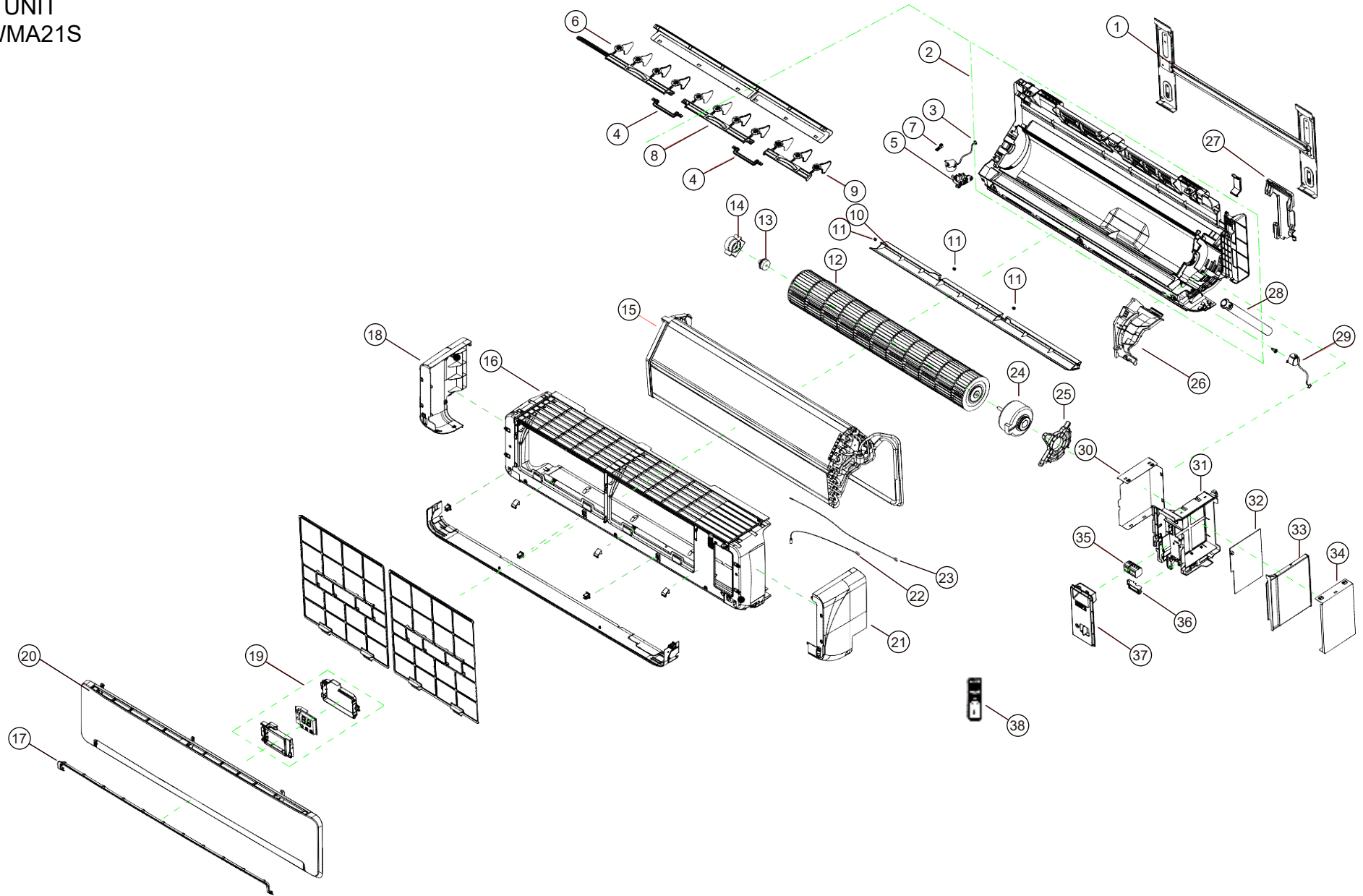

INDOOR UNIT
WHP24WMA21S

No.	Part number	Description
1	1907022	Bracket wall
2	1954365	Base assembly
3	1260311	Step motor
4	1541366	Holder center
5	1541373	Guard motor
6	1541456	Vertical louver
7	1541368	Holder center
8	1550291	Vertical louver
9	1550300	Vertical louver
10	1541363	Louver
11	1222824	Plug
12	1541633	Cross flow fan assy
13	1223738	Bearing
14	1465670	Baffle
15	1556041	Evaporator
16	1541382	Front panel
17	1826559	Ornamental part
18	1541388	Ornamental part
19	1824935	Display assembly
20	4151757	Intake grille
21	1541389	Ornamental part
22	1837499	Thermistor pipe
23	1896665	Thermistor pipe
24	1561456	Motor fan
25	1541374	Cover motor
26	1541375	Guard motor
27	1541361	Baffle
28	1470426	Drain hose
29	1819726	Step motor
30	1541500	Electric box cover
31	1870720	Electric box
32	1997858	Controller PCB
33	1541507	Cover wire
34	1837043	Cover wire
35	1852126	Terminal
36	1840141	Clamp cord
37	1541379	Cover display
38	4175260	Remote control
	1541387	Air filter

Cassette grille (Optional parts)

WH-AG4CT1

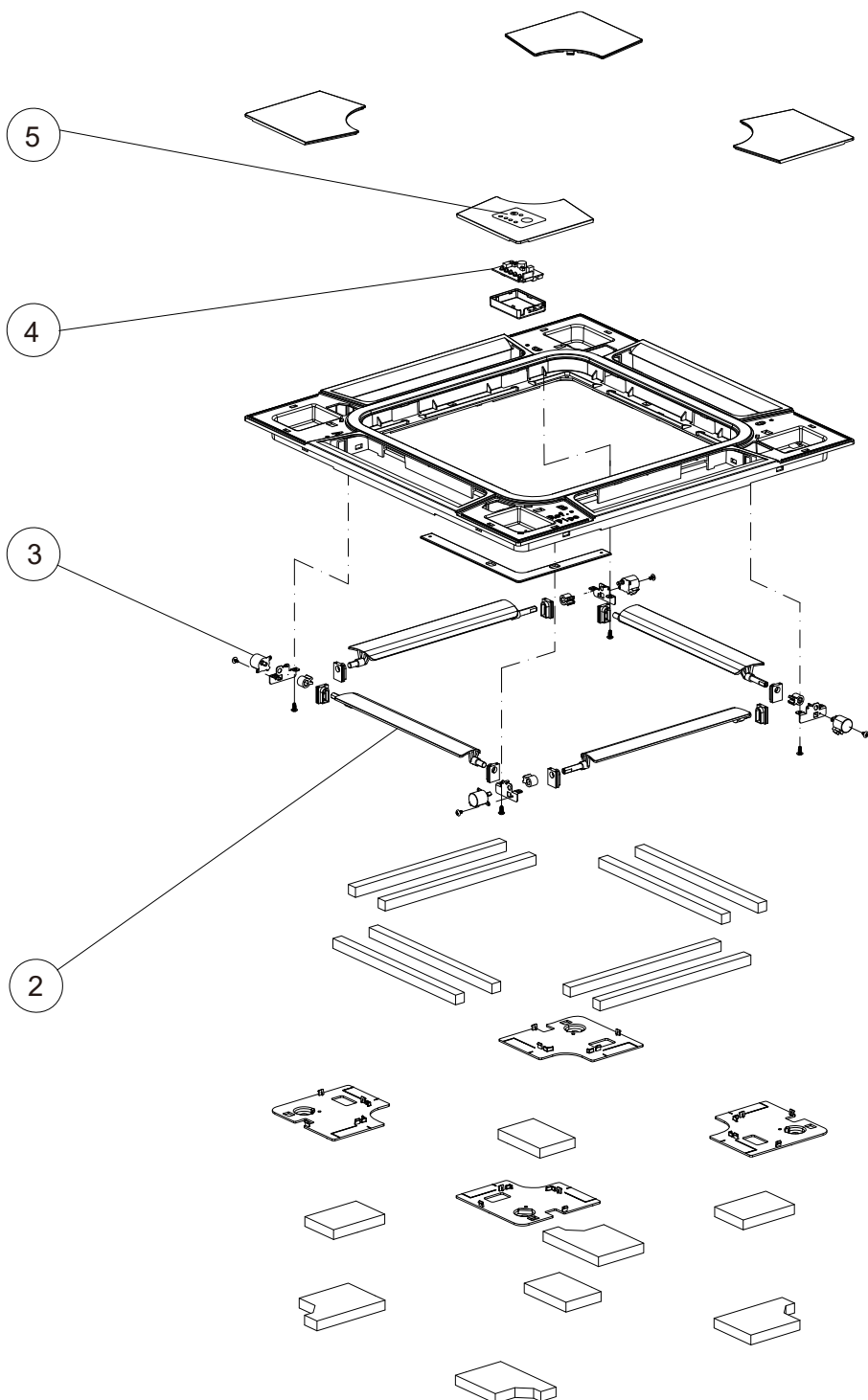
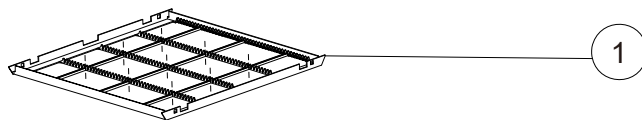
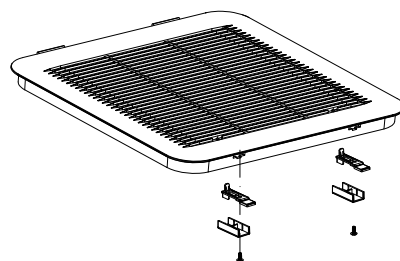
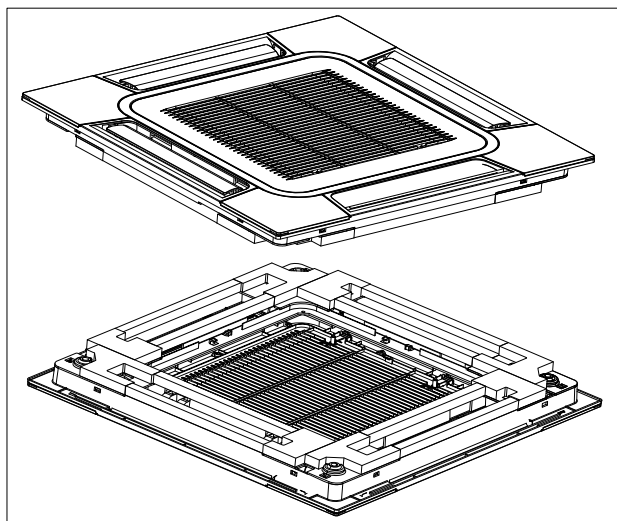

Cassette grille (Optional parts)
WH-AG4CT1

No.	Part number	Description
1	2006699	Filter net
2	2006714	Louver assy
3	1520252	Step motor
4	1984063	Indicator PCB
5	2008040	Display panel

Cassette grille (Optional parts)

WH-AG4CT2

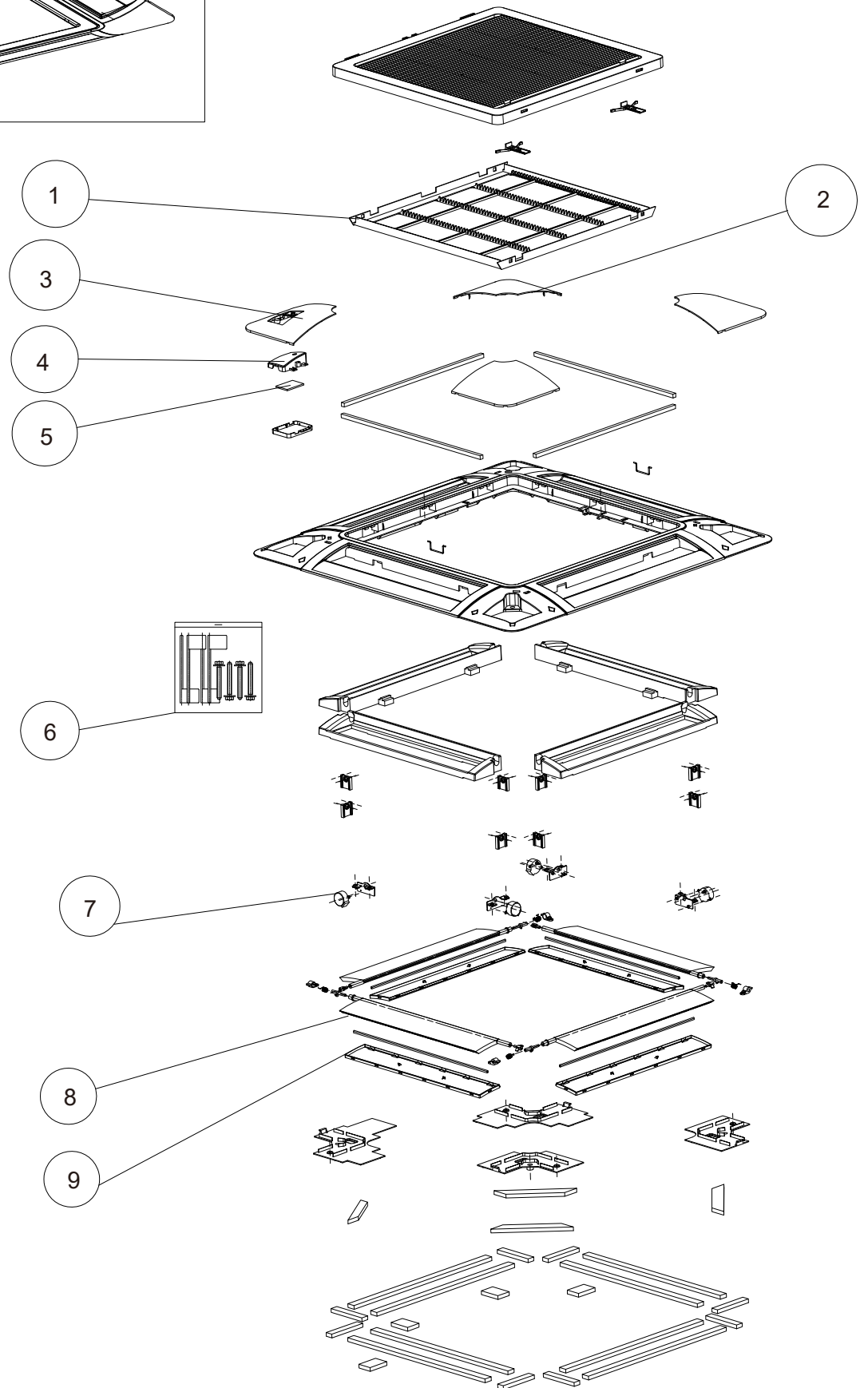
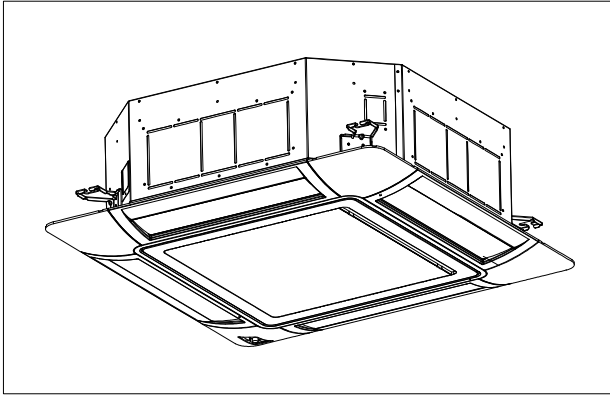

Cassette grille (Optional parts)
WH-AG4CT2

No.	Part number	Description
1	1525479	Filter net
2	1525469	Panel cover
3	1525470	Sealed plate
4	1571013	Display window
5	1570971	Indicator PCB
6	1416317	Accessory parts
7	1557789	Step motor
8	1525472	Louver assy
9	1525599	Flap assy

Indoor unit

WHU09CTA21S

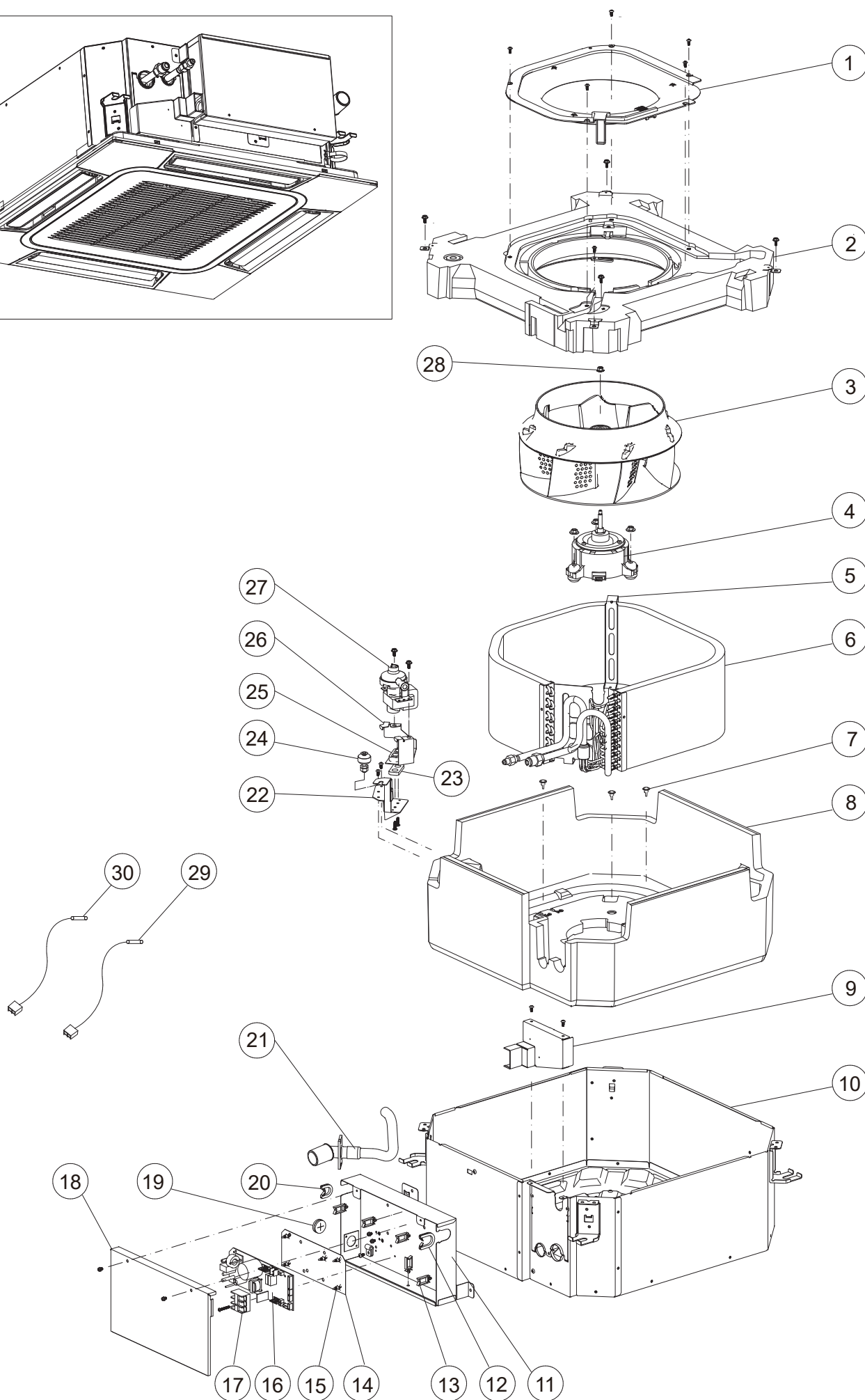
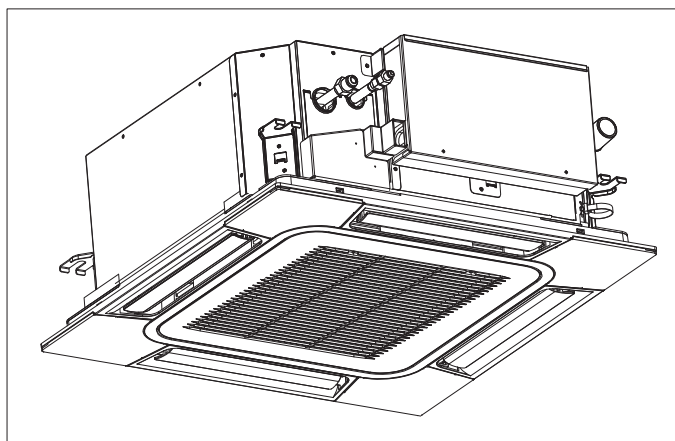

Indoor unit
WHU09CTA21S

No.	Part number	Description
1	2011390	Bell-mouth hood
2	2011371	Drain pan assembly
3	2011401	Turbo fan
4	1990901	Fan motor
5	2013213	Evaporator holder
6	2012933	Evaporator assembly
7	2013313	Screw
8	2013311	Insulation box
9	2013345	Fixed board
10	2009693	Cabinet
11	2013219	Electric box
12	1202700	Clamp
13	1471693	Clamp
14	1413386	Insulative spacer
15	1204016	Supporting leg
16	2024404	Controller PCB
17	1993154	Wire terminal board
18	2013221	Electric box cover
19	1865380	Rubber ring
20	1427802	Over clamp
21	2009724	Drain pipe assembly
22	2013245	Fixed board
23	1263263	Rubber cushion
24	1362154	Float switch
25	1263264	Rubber cushion
26	2013244	Mounting plate
27	1397768	Pump motor
28	1226721	Nut
29	1822633	Thermistor pipe
30	2004927	Temperature sensor
—	4175260	Remote control

Indoor unit
WHU12CTA21S

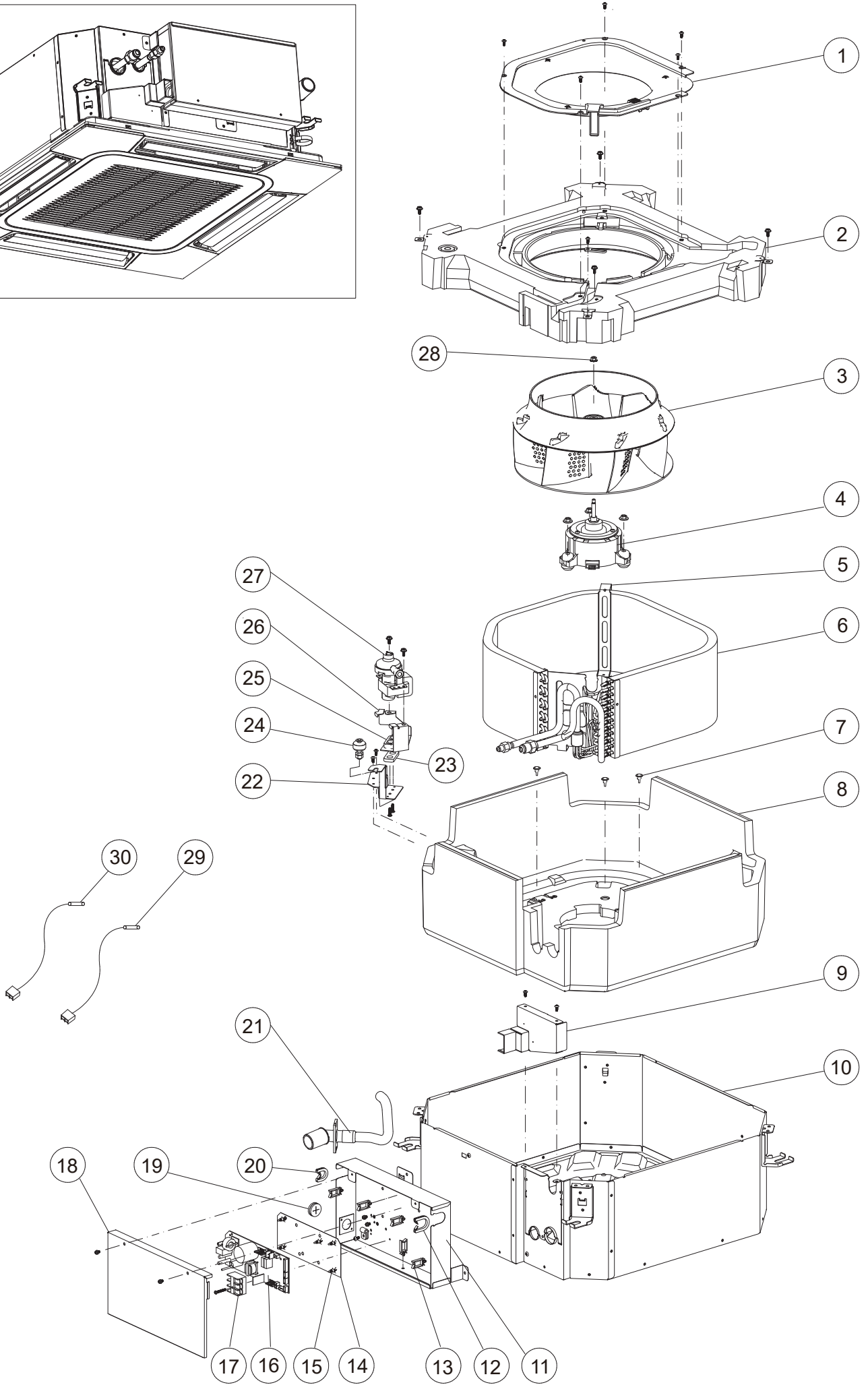
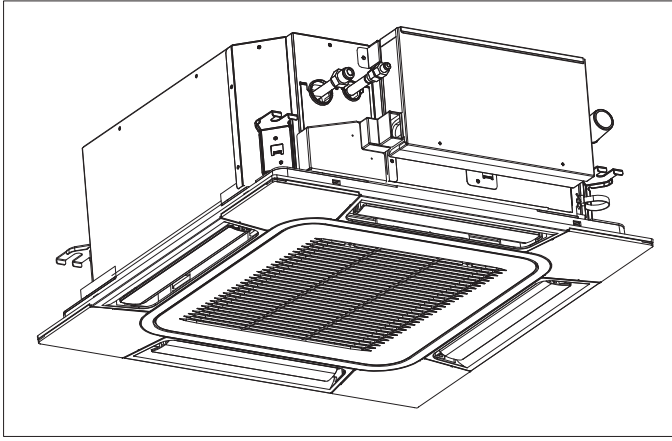

Indoor unit
WHU12CTA21S

No.	Part number	Description
1	2011390	Bell-mouth hood
2	2011371	Drain pan assembly
3	2011401	Turbo fan
4	1990901	Fan motor
5	2013213	Evaporator holder
6	2012580	Evaporator assembly
7	2013313	Screw
8	2013311	Insulation box
9	2013345	Fixed board
10	2009693	Cabinet
11	2013219	Electric box
12	1202700	Clamp
13	1471693	Clamp
14	1413386	Insulative spacer
15	1204016	Supporting leg
16	2024421	Controller PCB
17	1993154	Wire terminal board
18	2013221	Electric box cover
19	1865380	Rubber ring
20	1427802	Over clamp
21	2009724	Drain pipe assembly
22	2013245	Fixed board
23	1263263	Rubber cushion
24	1362154	Float switch
25	1263264	Rubber cushion
26	2013244	Mounting plate
27	1397768	Pump motor
28	1226721	Nut
29	1822633	Thermistor pipe
30	2004927	Temperature sensor
—	4175260	Remote control

Indoor unit
WHU18CTA21S

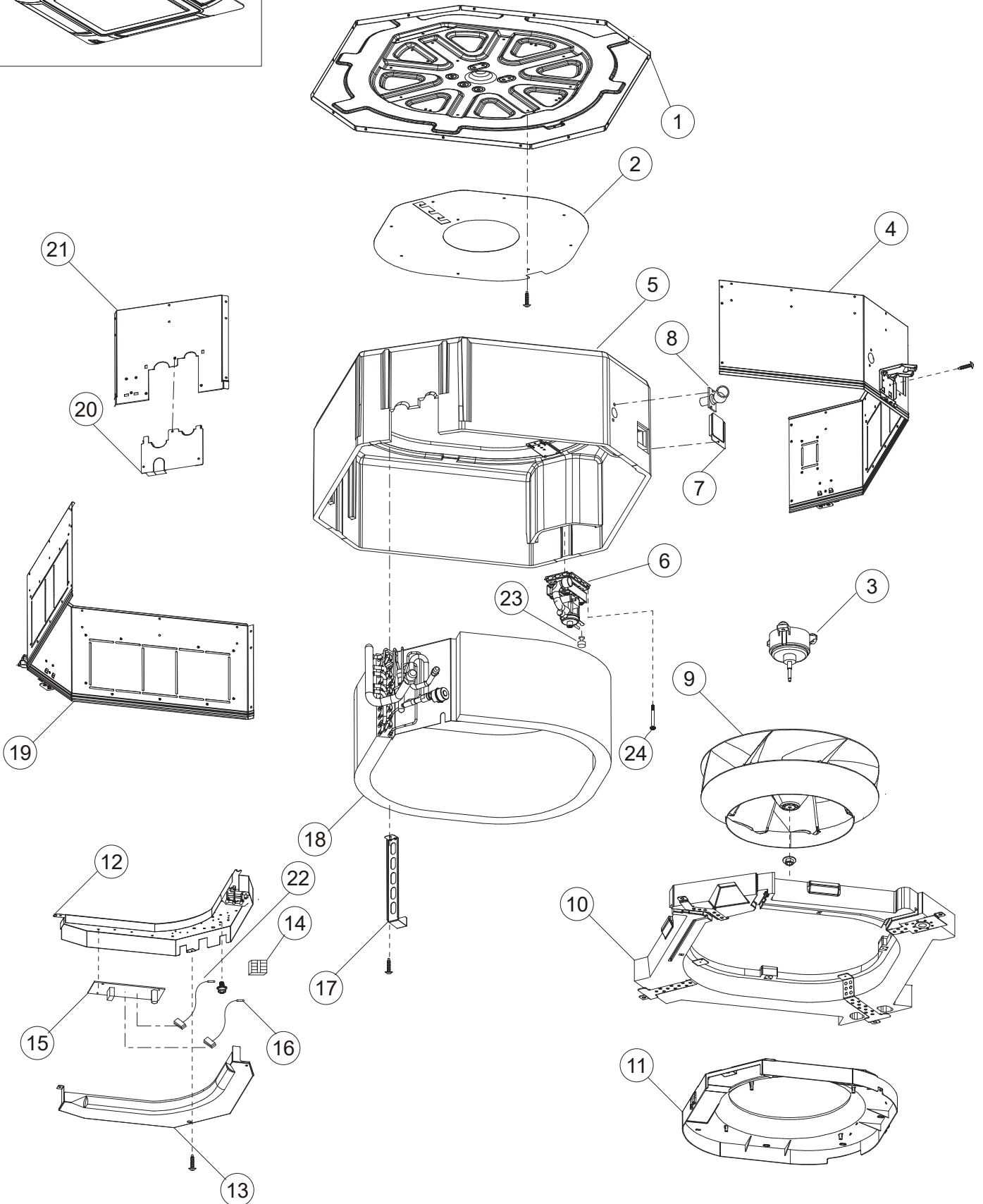
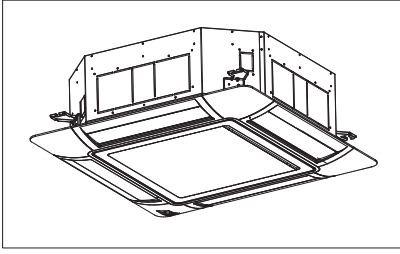

Indoor unit
WHU18CTA21S

No.	Part number	Description
1	1913587	Top plate
2	1416128	Air duct plate
3	1457336	Fan motor
4	1509697	Cabinet
5	1510003	Insulation box
6	1514478	Pump motor
7	1515344	Cover
8	1515168	Drain hose
9	1416022	Turbo fan
10	1415899	Drain pan assembly
11	1416026	Bell-mouth hood
12	2014260	Electric box
13	1415950	Electric box cover
14	1993154	Wire terminal board
15	2012823	Controller PCB
16	1413278	Thermistor coil
17	1416411	Evaporator holder
18	2107688	Evaporator assembly
19	1509696	Cabinet
20	1515050	Connecting plate
21	1509699	Side panel
22	1428008	Thermistor room
23	1362154	Float switch
24	1462582	Screw
—	4175260	Remote control

Indoor unit
WHU24CTA21S

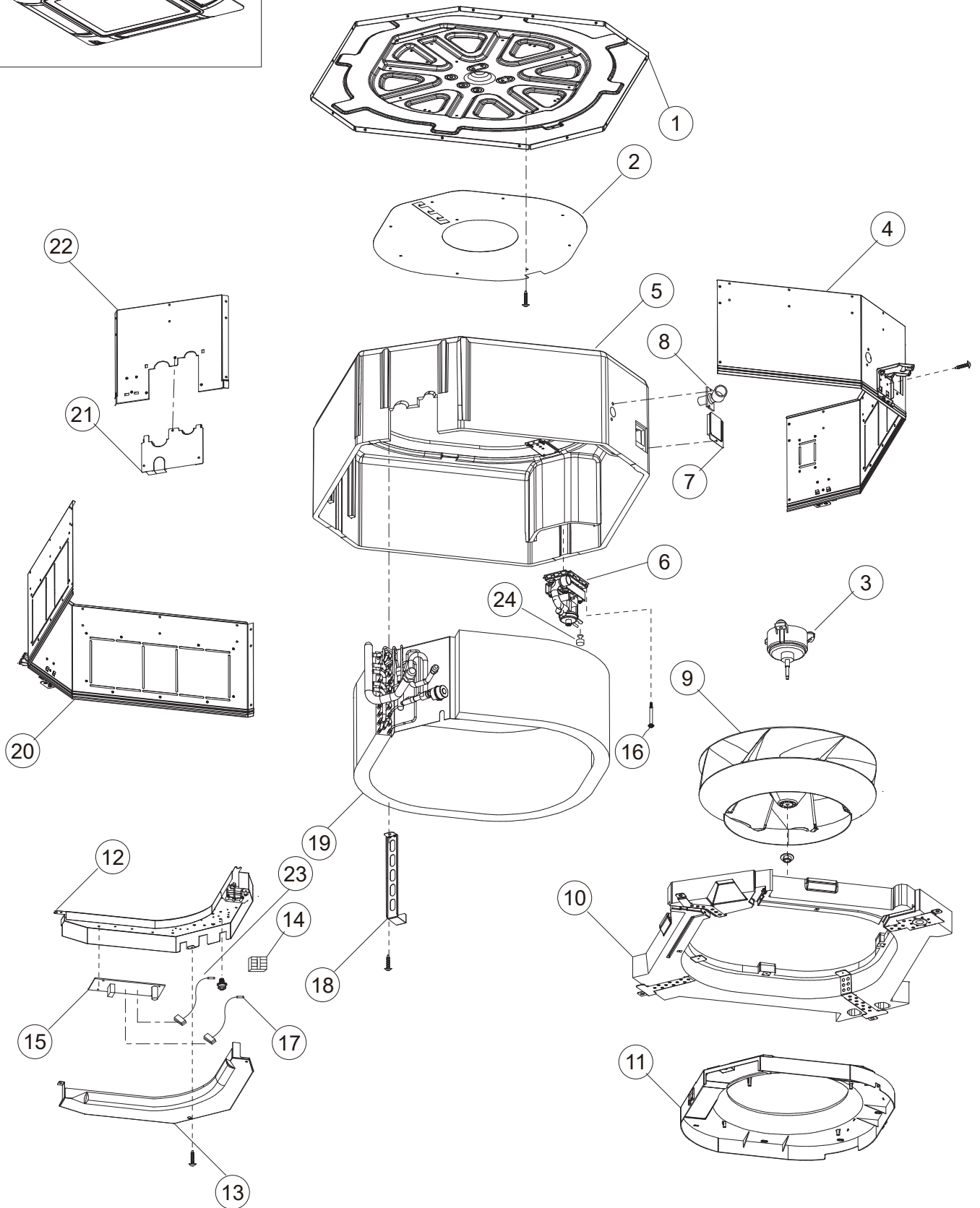
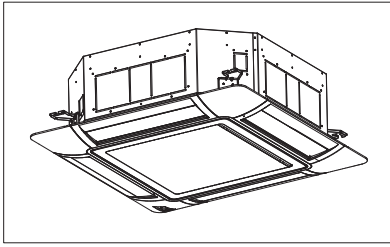

Indoor unit
WHU24CTA21S

No.	Part number	Description
1	1913587	Top plate
2	1416128	Air duct plate
3	1457336	Fan motor
4	1509697	Cabinet
5	1510003	Insulation box
6	1514478	Pump motor
7	1515344	Cover
8	1515168	Drain hose
9	1416022	Turbo fan
10	1415899	Drain pan assembly
11	1416026	Bell-mouth hood
12	2014260	Electric box
13	1415950	Electric box cover
14	1993154	Wire terminal board
15	2009348	Controller PCB
16	1462582	Screw
17	1413278	Thermistor coil
18	1416088	Evaporator holder
19	1526285	Evaporator assembly
20	1509696	Cabinet
21	1515050	Connecting plate
22	1509699	Side panel
23	1428008	Thermistor room
24	1362154	Float switch
—	4175260	Remote control

Indoor unit
WHU09DHA21S

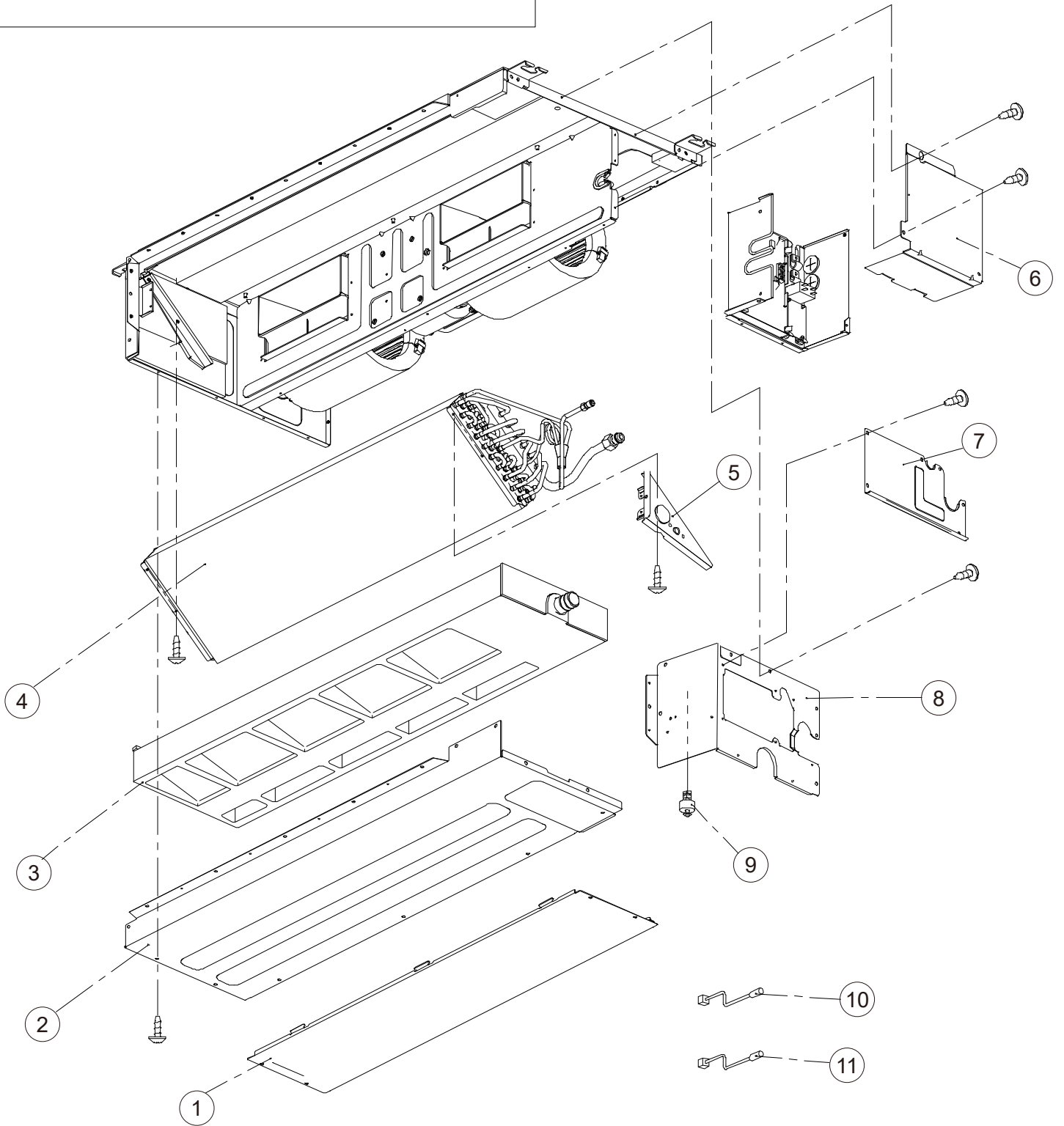
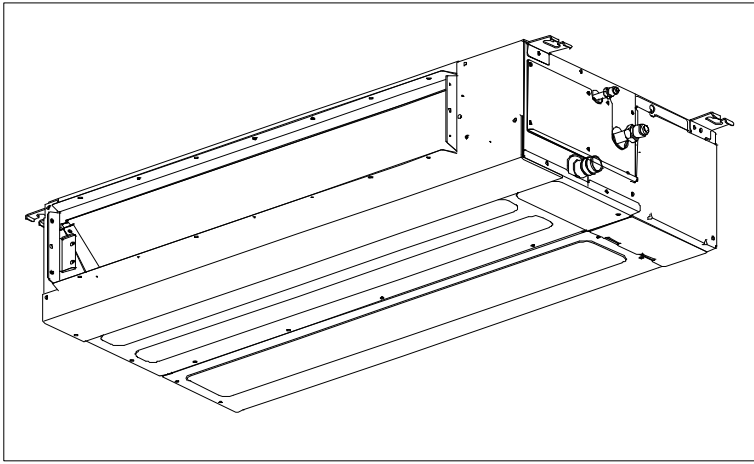

< Fan >

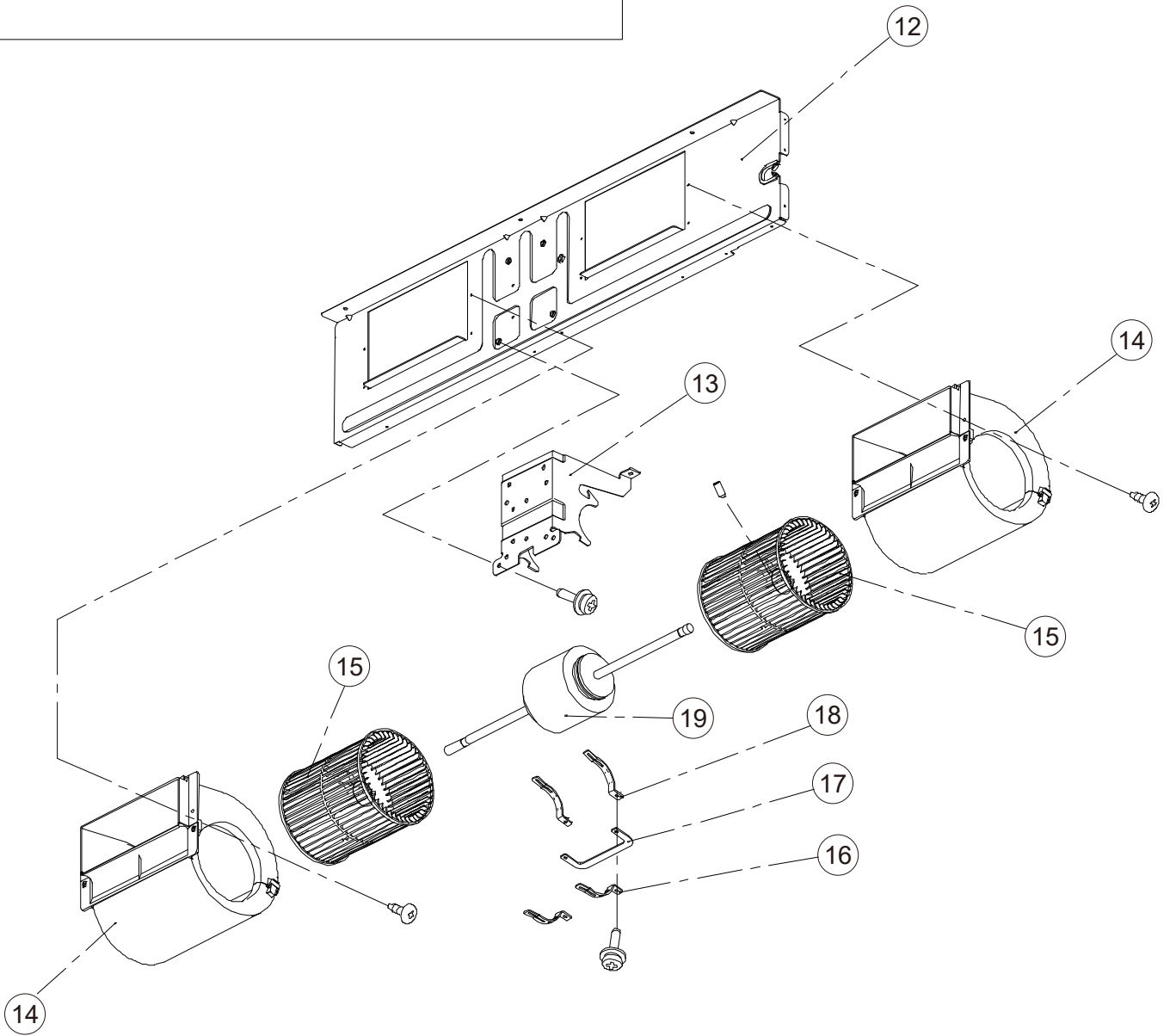
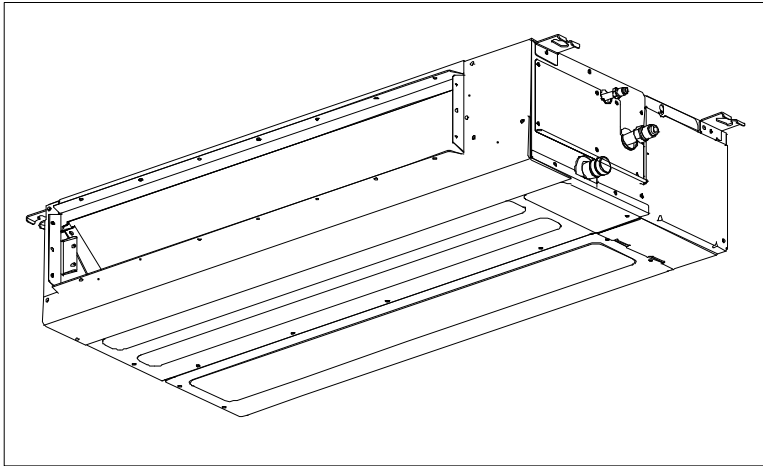

< Electrical parts >

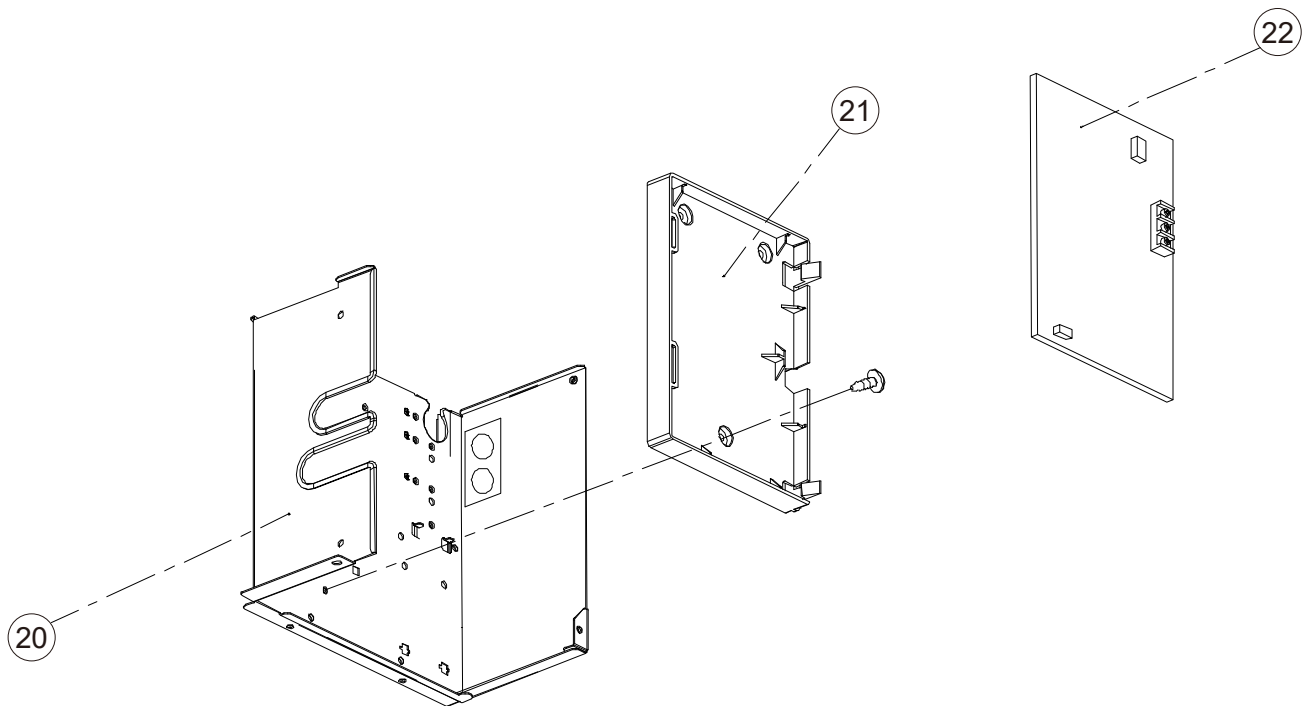
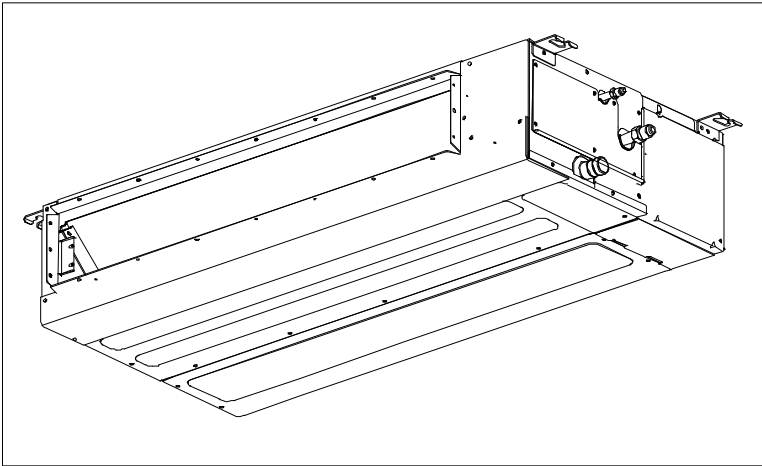

Indoor unit
WHU09DHA21S

No.	Part number	Description
1	1969154	Base panel
2	1969155	Bottom panel
3	1993005	Drain pan
4	1995110	Evaporator assembly
5	1998962	Supporting
6	1969103	Electric box cover
7	1996833	Seal panel
8	1967872	Right side panel
9	1976778	Float switch
10	1896665	Thermistor pipe
11	1858534	Temperature sensor
12	1992634	Fan panel
13	1992632	Motor bracket
14	1969168	Casing
15	1969181	Sirocco fan
16	1537916	Hooking
17	1987436	Connecting rod
18	1537915	Hooking
19	1917577	Fan motor
20	2011752	Electric box
21	2011732	Electric box
22	2012541	Controller PCB
—	1964450	Pump motor
—	2015192	Filter net assembly

Indoor unit
WHU12DHA21S

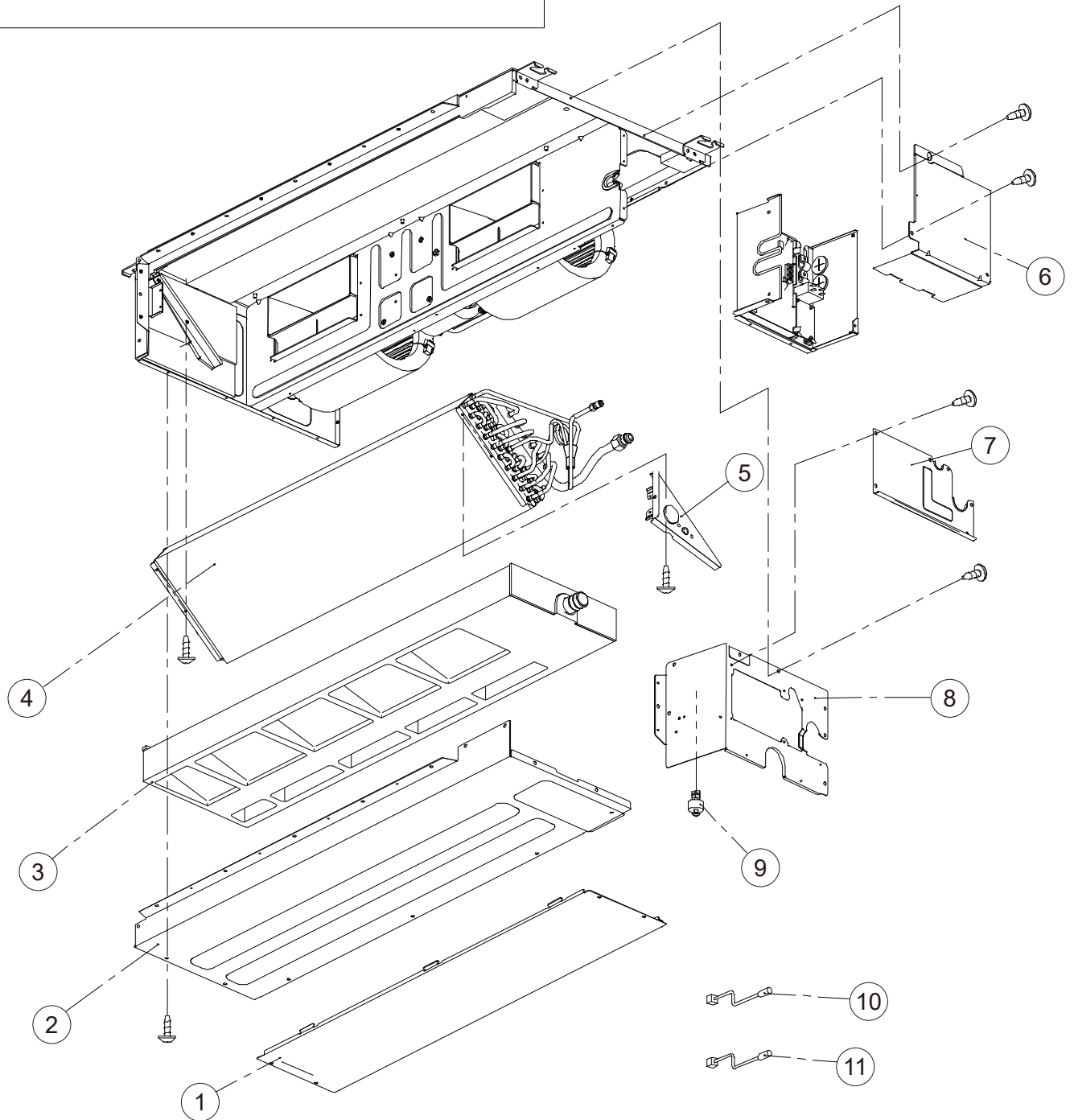
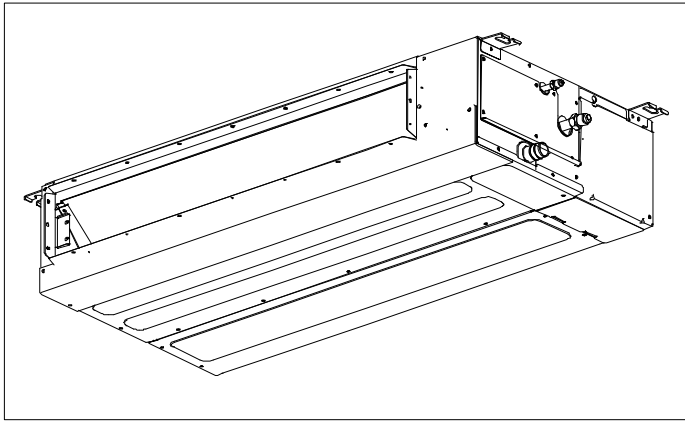

< Fan >

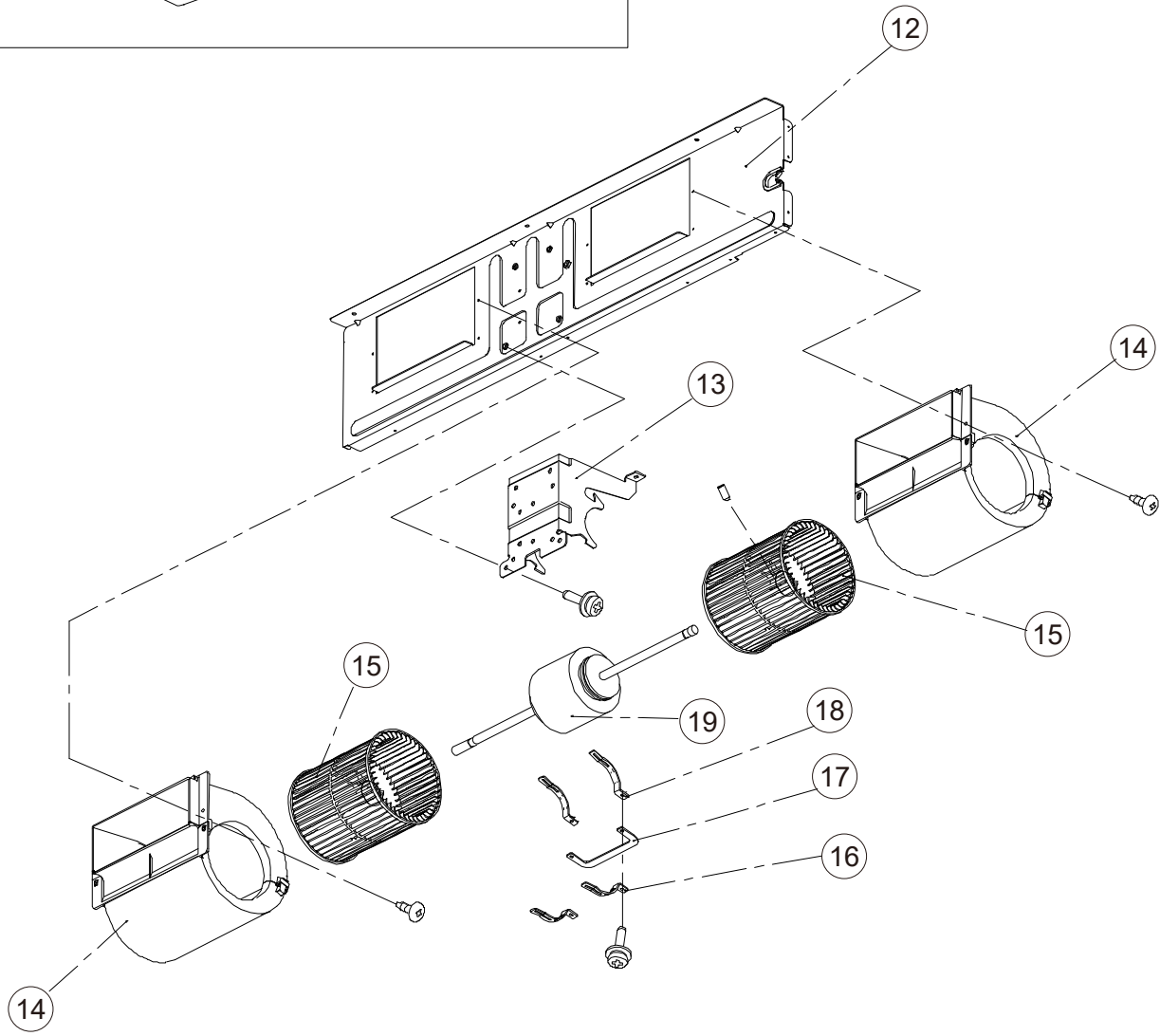
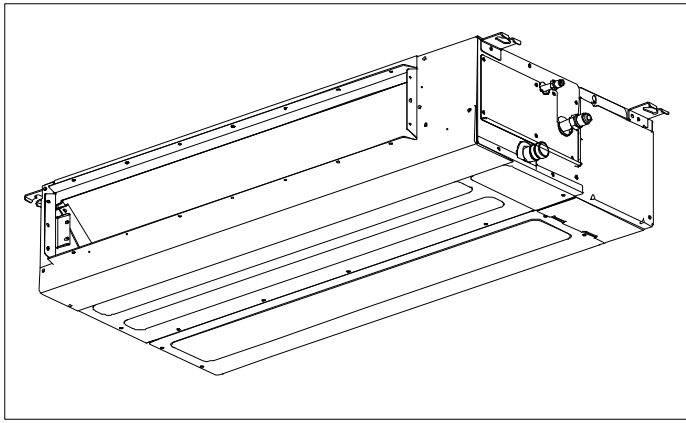

< Electrical parts >

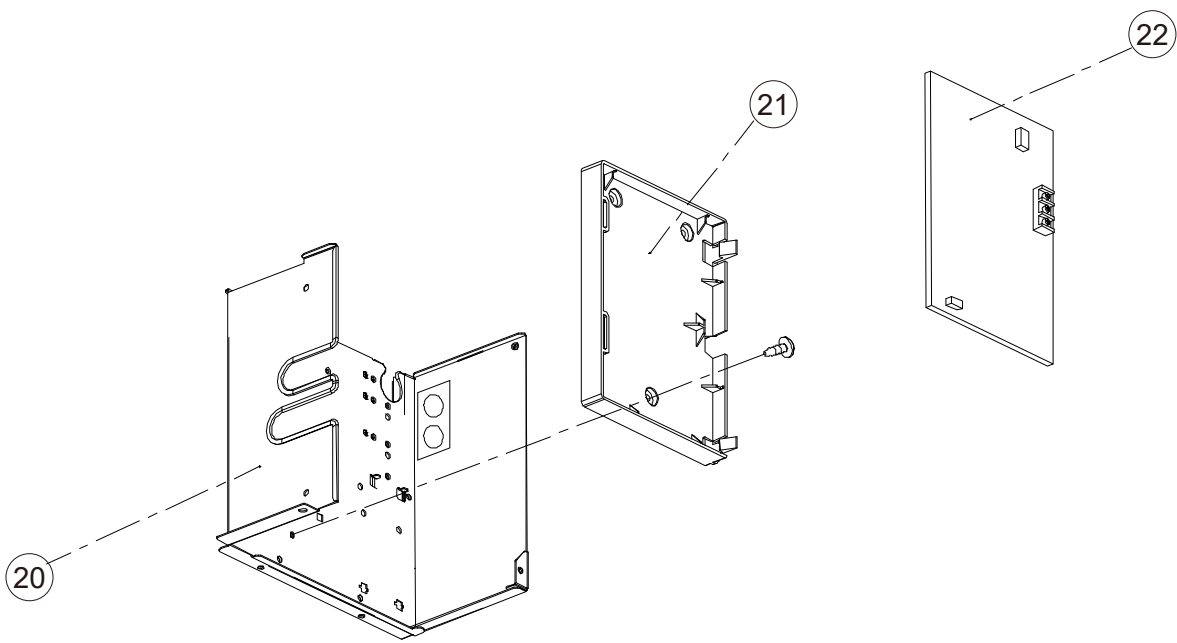
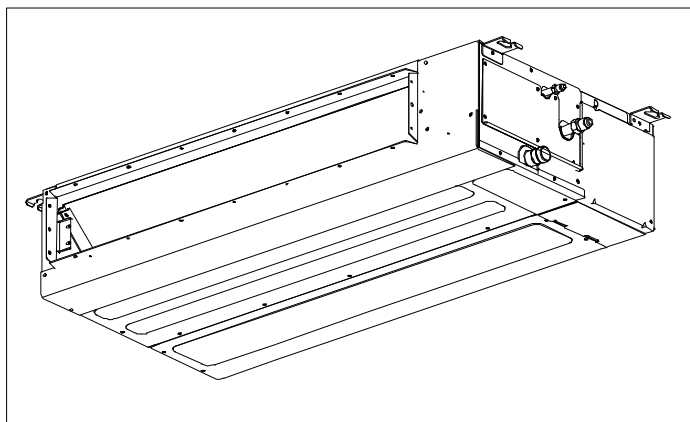

Indoor unit
WHU12DHA21S

No.	Part number	Description
1	1969154	Base panel
2	1969155	Bottom panel
3	1993005	Drain pan
4	1995110	Evaporator assembly
5	1998962	Supporting
6	1969103	Electric box cover
7	1996833	Seal panel
8	1967872	Right side panel
9	1976778	Float switch
10	1896665	Thermistor pipe
11	1858534	Temperature sensor
12	1992634	Fan panel
13	1992632	Motor bracket
14	1969168	Casing
15	1969181	Sirocco fan
16	1537916	Hooking
17	1987436	Connecting rod
18	1537915	Hooking
19	1917577	Fan motor
20	2011752	Electric box
21	2011732	Electric box
22	2012544	Controller PCB
—	1964450	Pump motor
—	2015192	Filter net assembly

Indoor unit
WHU18DHA21S

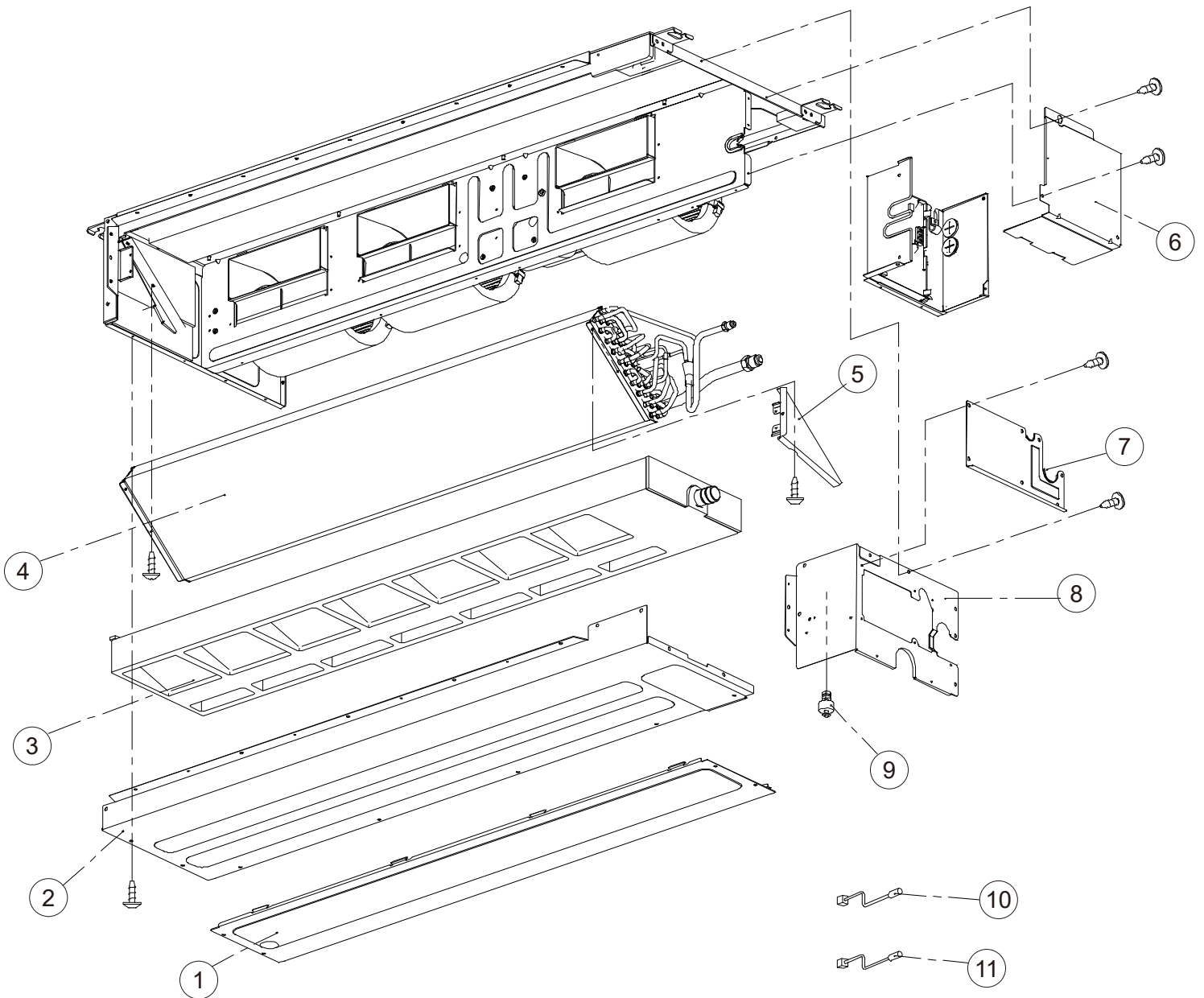
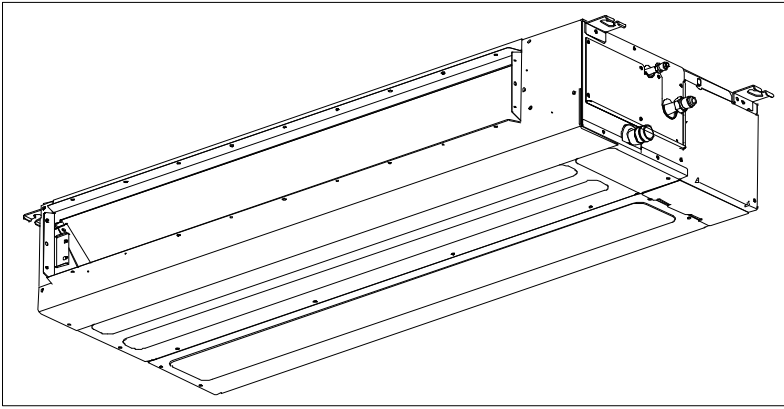

< Fan >

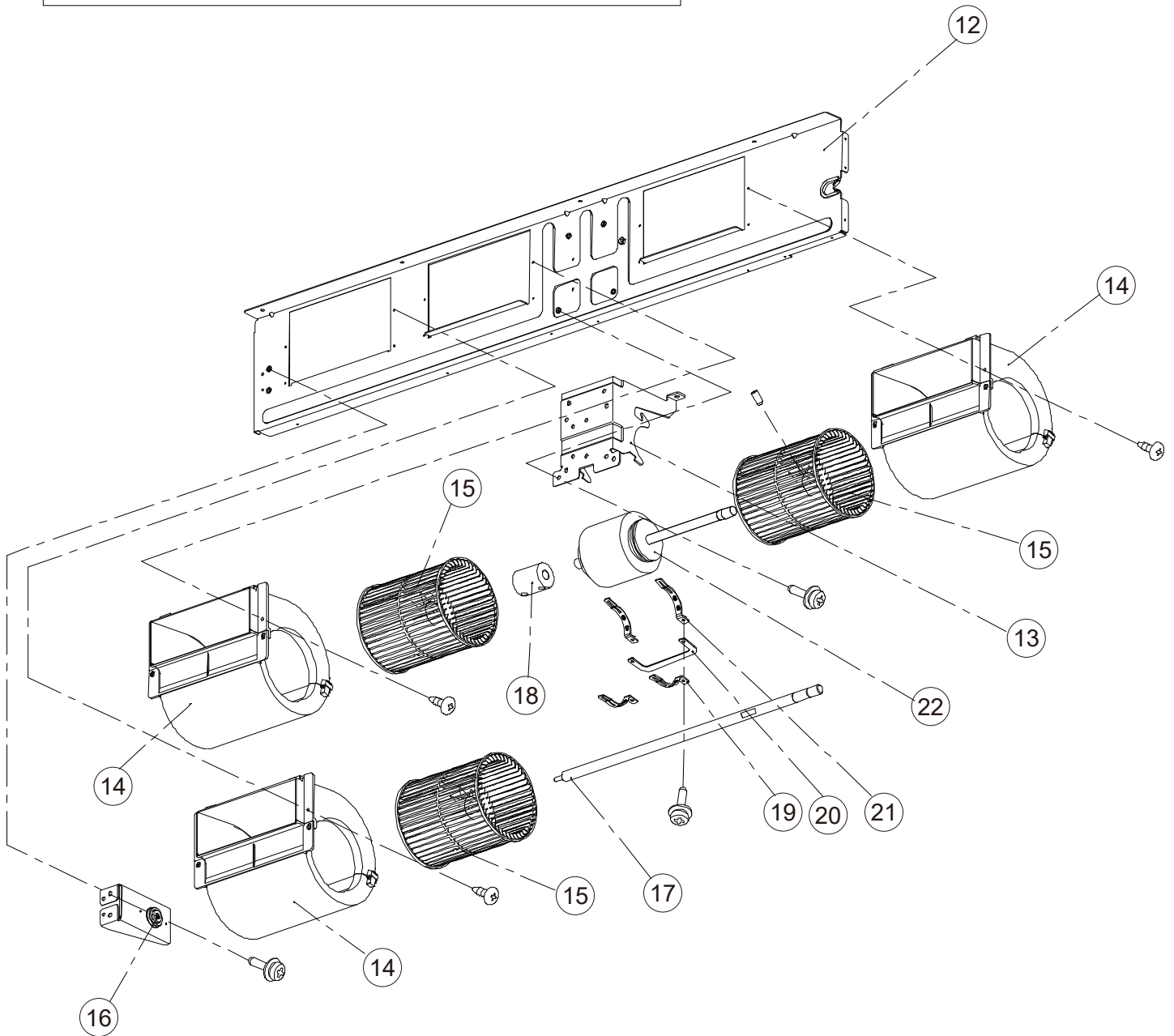
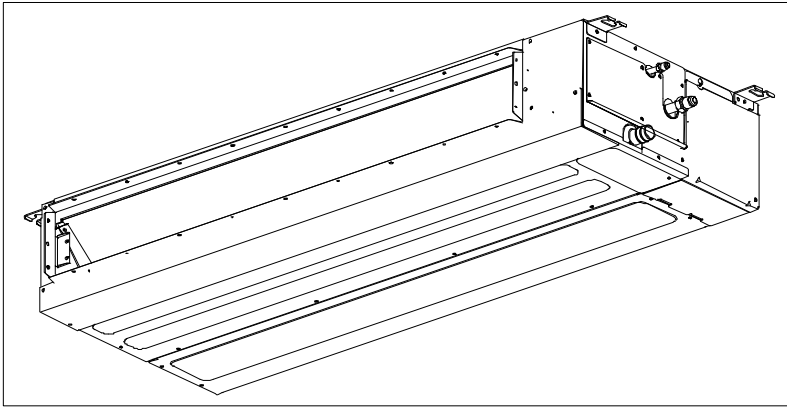

< Electrical parts >

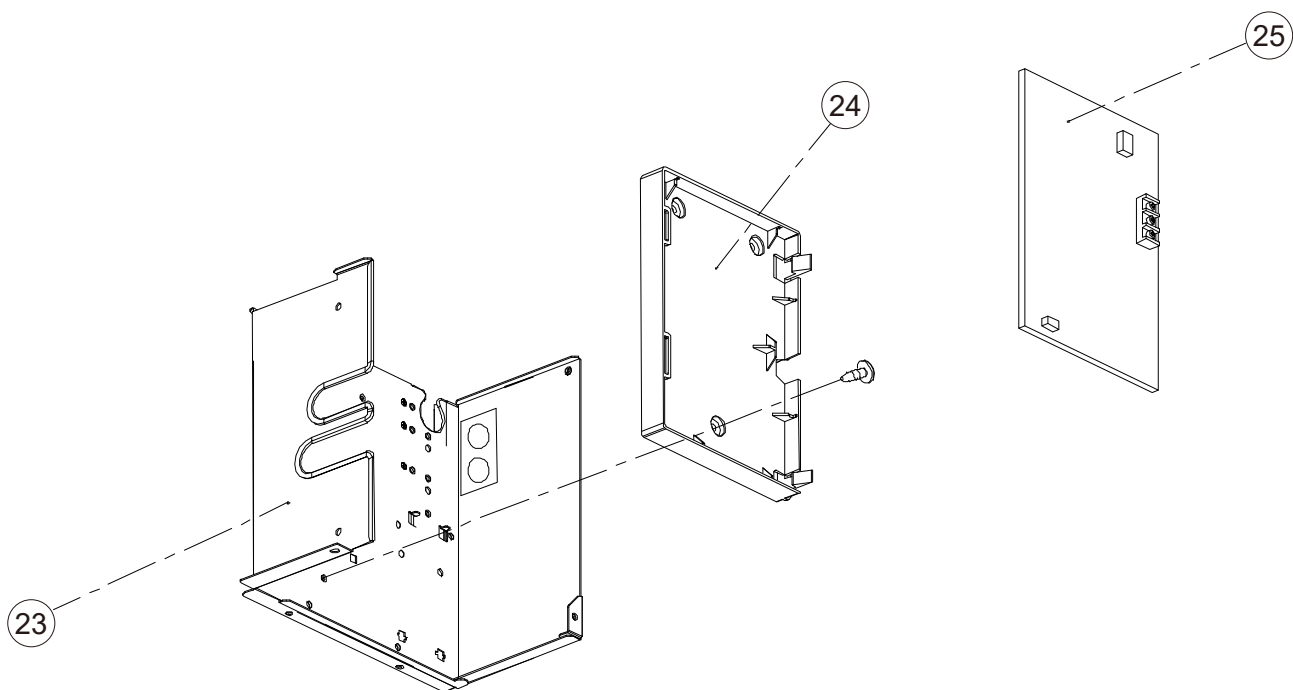
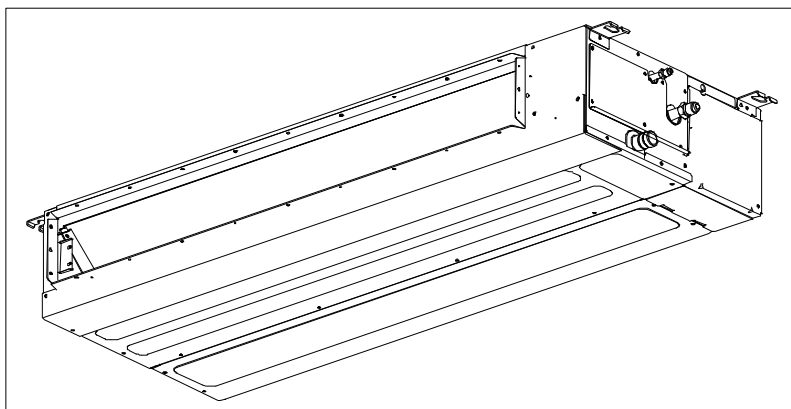

Indoor unit
WHU18DHA21S

No.	Part number	Description
1	1969208	Base panel
2	1969213	Bottom panel
3	1993004	Drain pan
4	1995617	Evaporator assembly
5	1998962	Supporting
6	1969103	Electric box cover
7	1968772	Seal panel
8	1967872	Right side panel
9	1976778	Float switch
10	1896665	Thermistor pipe
11	1858534	Temperature sensor
12	1992634	Fan panel
13	1992632	Motor bracket
14	1969168	Casing
15	1969181	Sirocco fan
16	1438648	Bearing
17	1969002	Shaft
18	2101914	Crosshead
19	1537916	Hooking
20	1987436	Connecting rod
21	1537915	Hooking
22	1917578	Fan motor
23	2011752	Electric box
24	2011732	Electric box
25	2012617	Controller PCB
—	1964450	Pump motor
—	2015193	Filter net assembly

Indoor unit
WHU24DHA21S

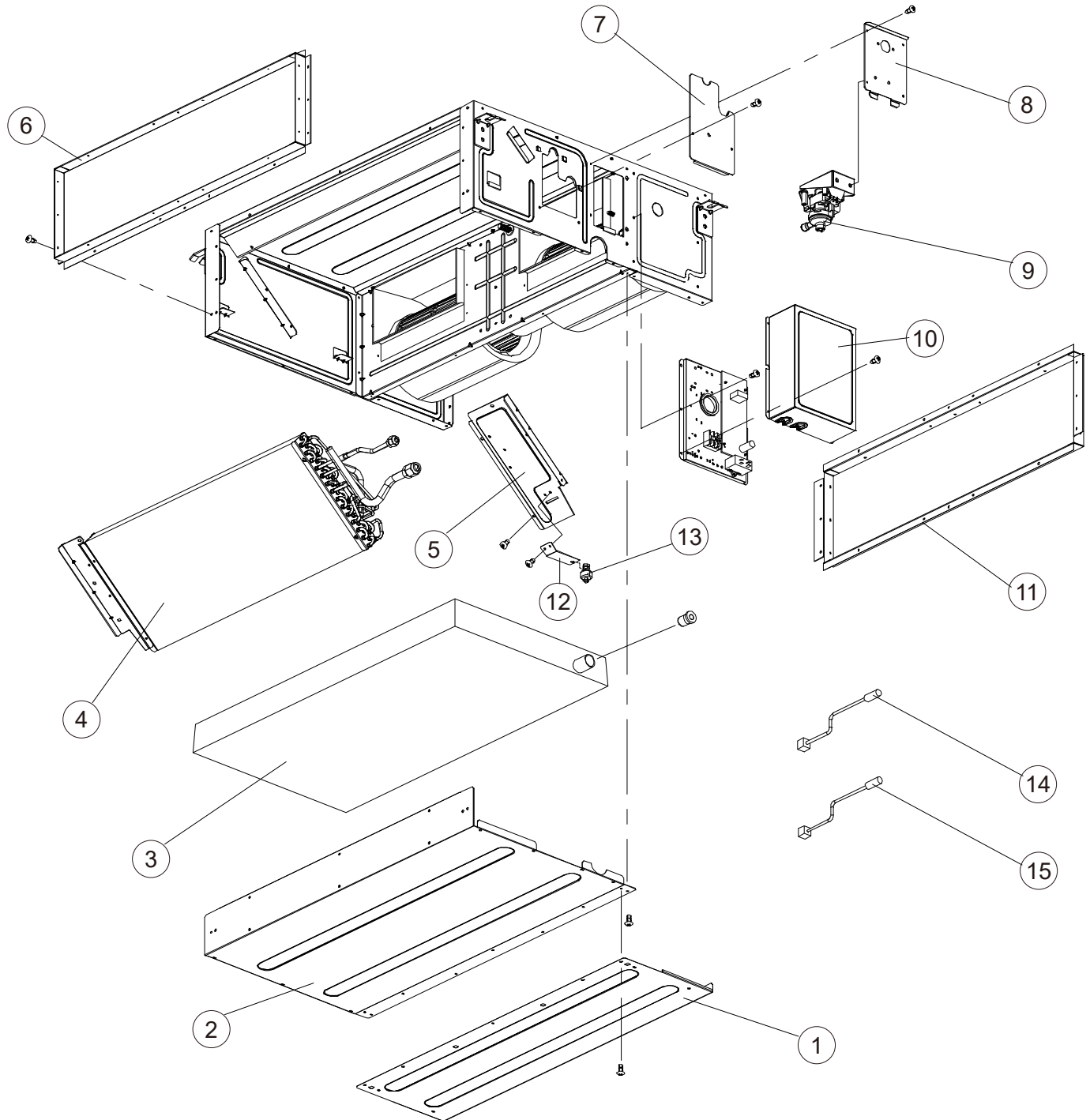
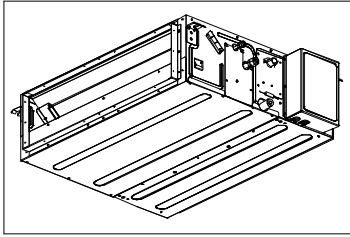

< Fan >

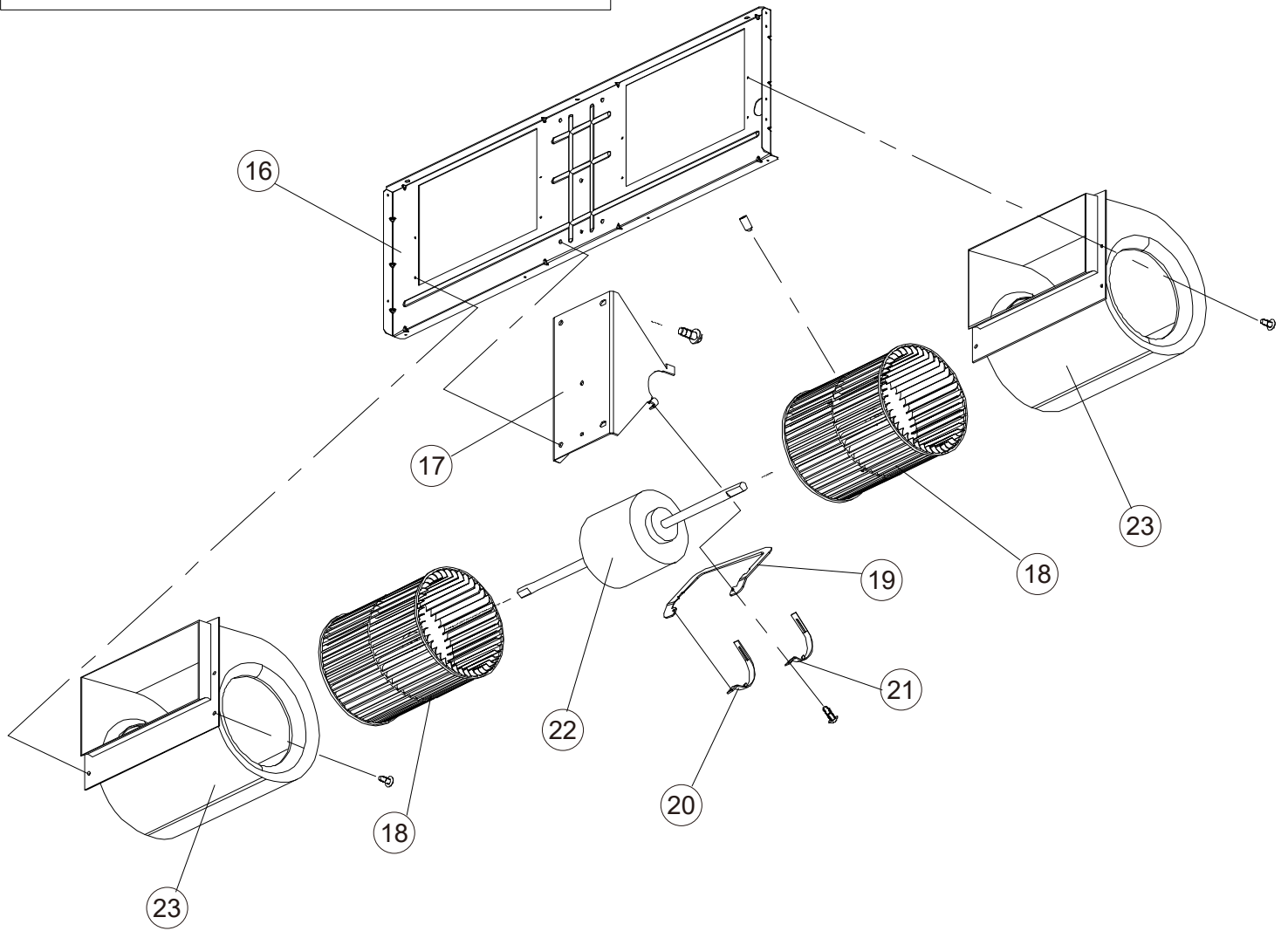
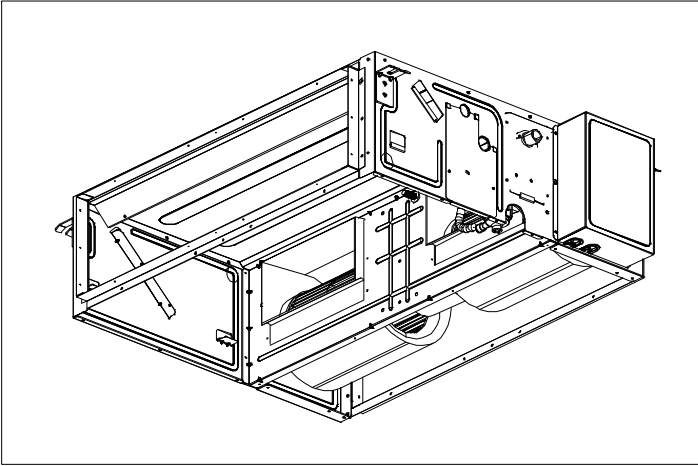

< Electrical parts >

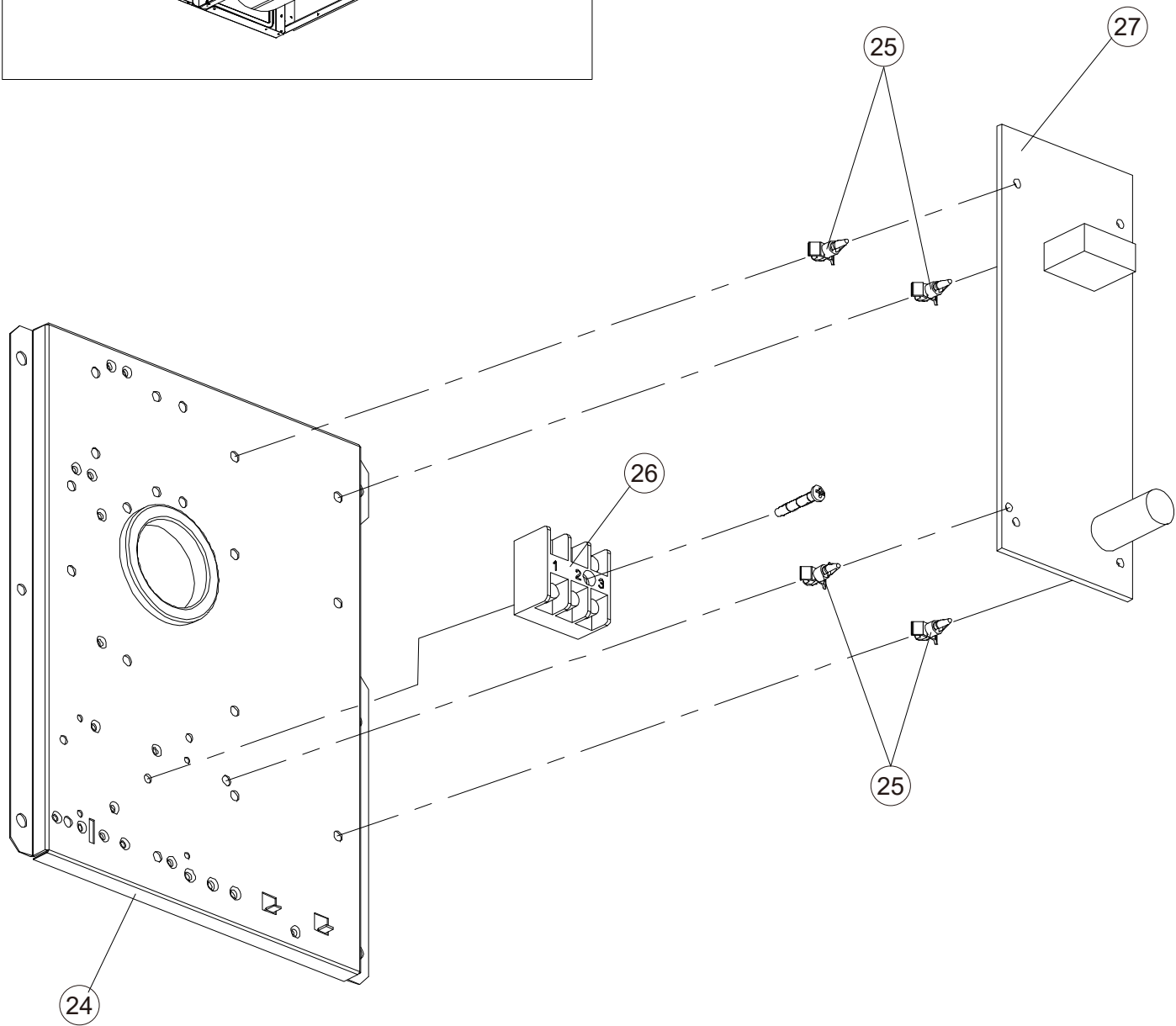
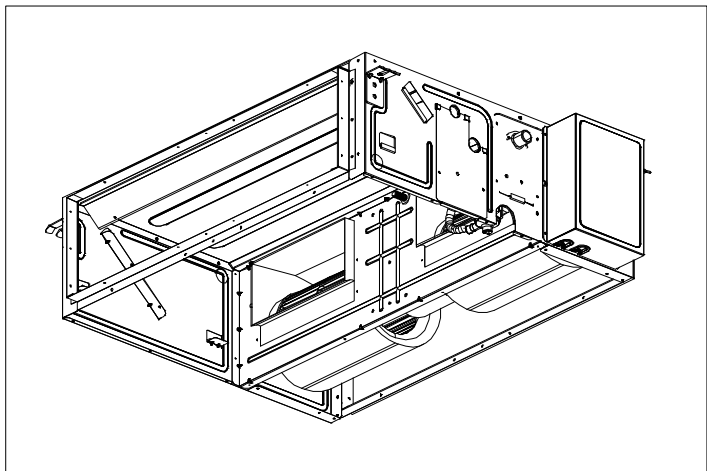

Indoor unit
WHU24DHA21S

No.	Part number	Description
1	1485017	Base panel
2	1492894	Bottom panel
3	1832798	Drain pan
4	1413268	Evaporator assembly
5	1819938	Supporting
6	1492871	Outlet frame AS
7	1947623	Supporting
8	1947645	Supporting
9	1832801	Pump motor
10	2080728	Electric box cover
11	1543710	Inlet frame assembly
12	1484976	Float bracket
13	1362154	Float switch
14	1413278	Thermistor coil
15	1473879	Thermistor room
16	1493086	Fan panel
17	1520388	Motor bracket
18	1382431	Sirocco fan
19	1568929	Connecting rod
20	1437981	Hooking
21	1437979	Hooking
22	1517301	Fan motor
23	1384111	Casing
24	1484990	Electric box
25	1204016	Supporting leg
26	1993154	Wire terminal board
27	2089145	Controller PCB
—	1543684	Filter net assembly

AS: assembly

OUTDOOR UNIT
WHP18M2A21S

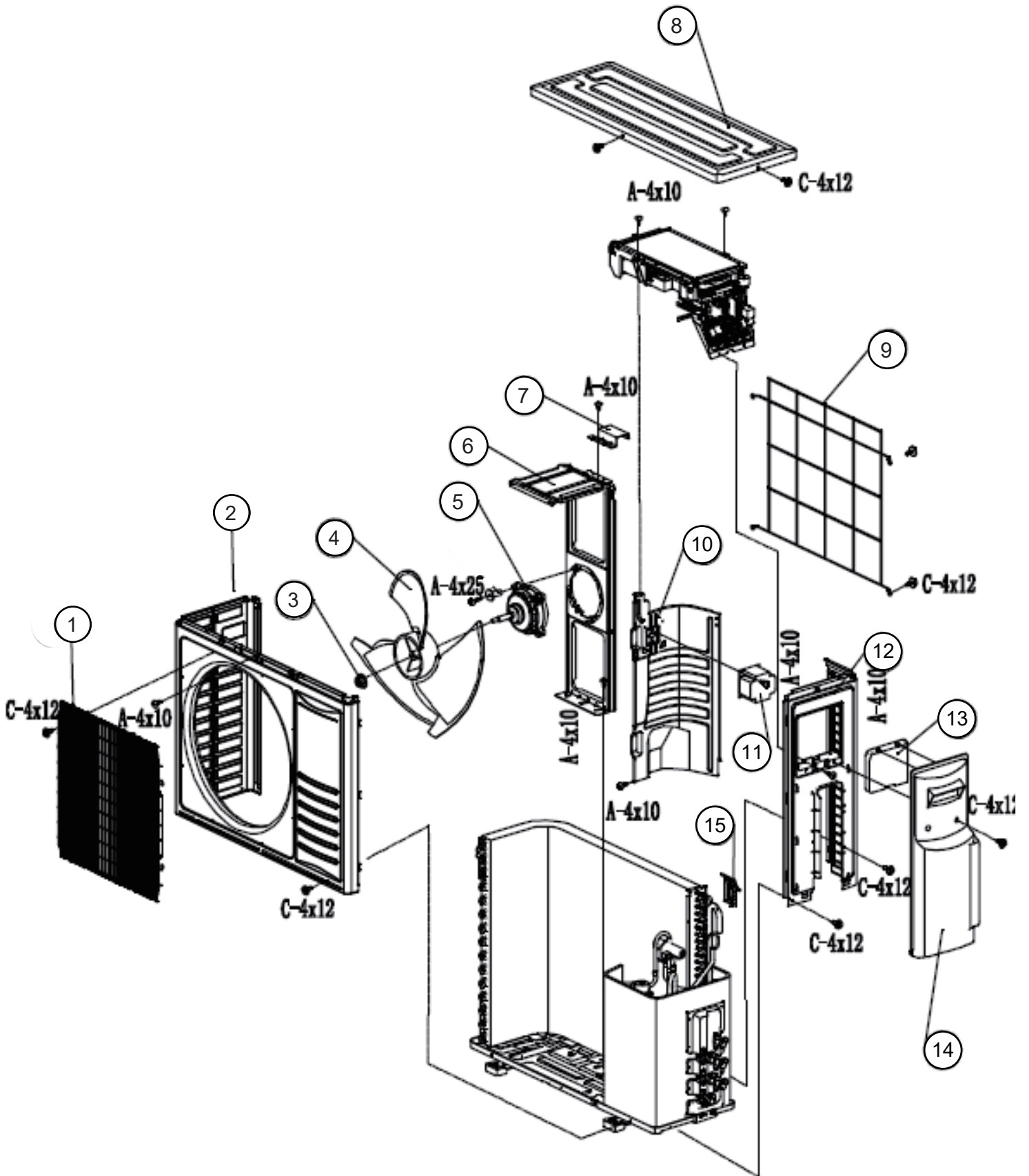

OUTDOOR UNIT
WHP18M2A21S

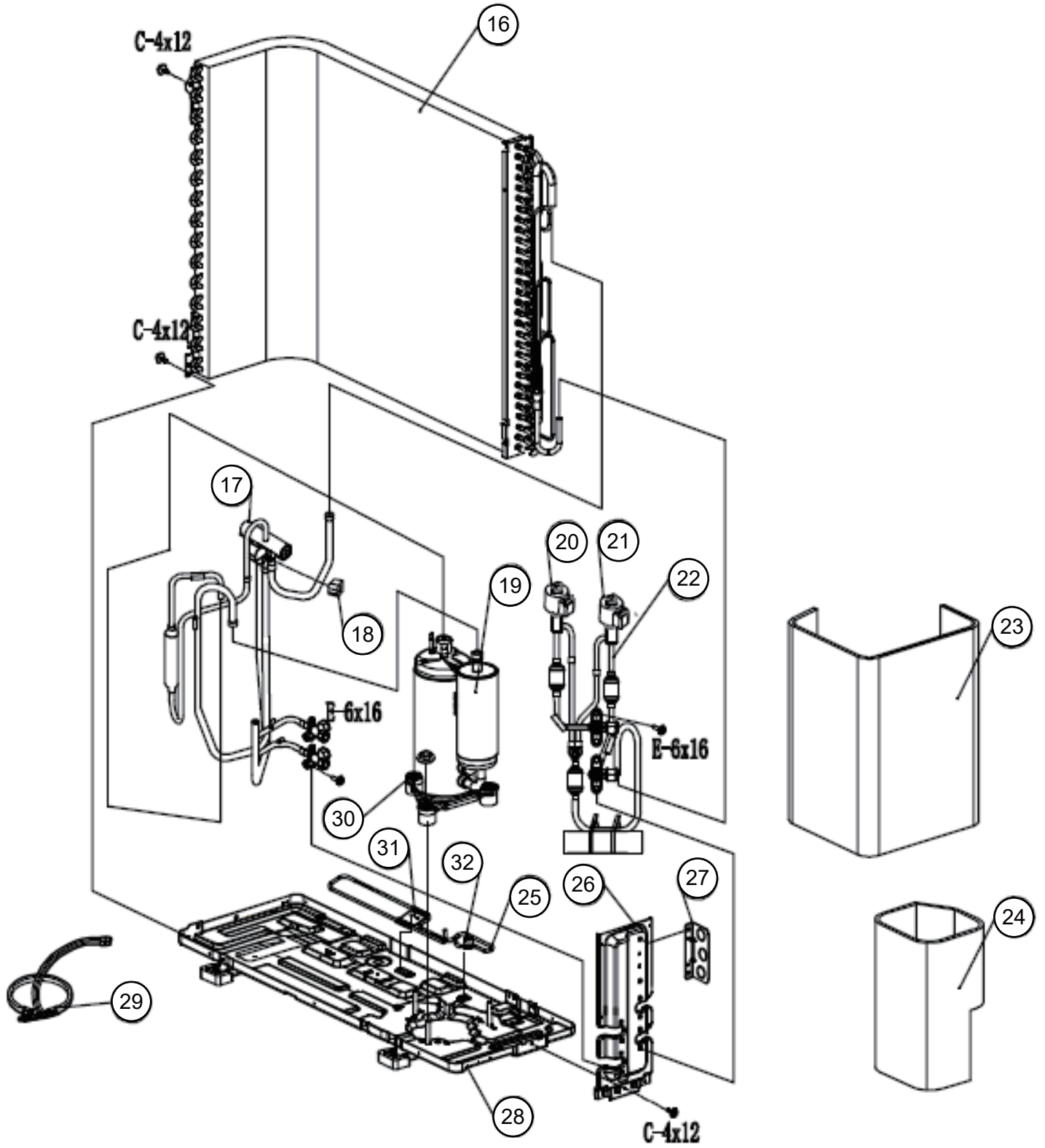

OUTDOOR UNIT
WHP18M2A21S

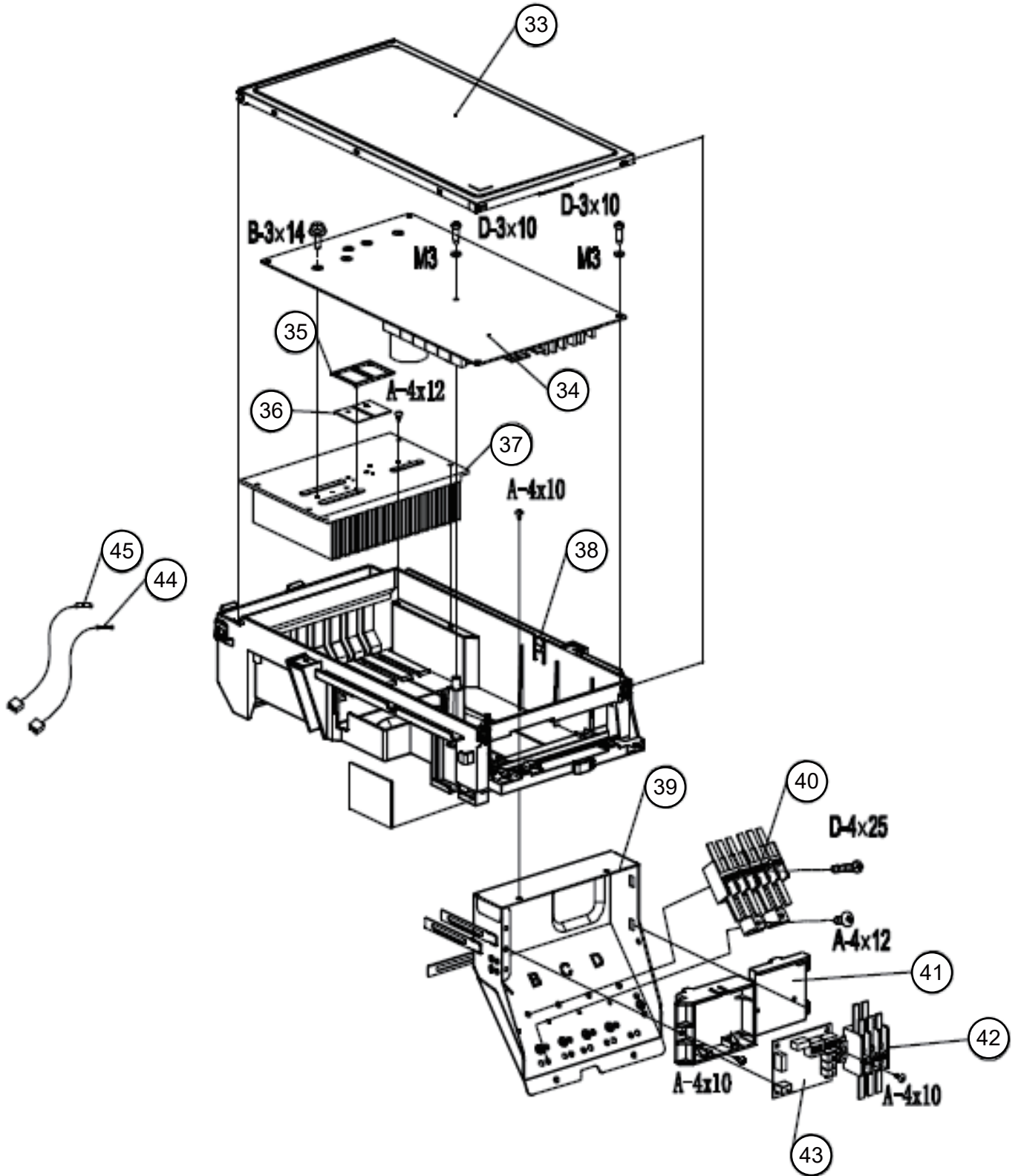

OUTDOOR UNIT
WHP18M2A21S

No.	Part number	Description
1	1844024	Fan guard
2	2091948	Intake grille
3	1263647	Nut
4	1559520	Propeller fan blade
5	1859837	DC motor
6	1963835	Motor bracket
7	1834430	Connecting board
8	1961485	Top panel
9	1929744	Protective net back
10	2087707	Separate wall
11	1302261	Choke coil
12	1982353	Cabinet right
13	1982356	Strengthen plate
14	1982355	Valve cover
15	1546721	Sensor mount plate
16	1983283	Condenser
17	2079329	Valve 4 way TA
18	1511783	Solenoid
19	2079361	Compressor
20	1980925	EEV coil
21	1980924	EEV coil
22	2079330	Outlet tube assembly
23	1474127	Soundproof cotton

No.	Part number	Description
24	1948346	Soundproof cotton
25	1854710	Tube electric heater
26	2083031	Mounting plate
27	2083034	Mounting plate
28	2080343	Base holder
29	1928912	Crankcase heater
30	1203995	Hex nuts
31	1807108	Mounting plate
32	1854042	fixing clip
33	1982348	Cover wire
34	2078746	Inverter control PCB
35	1487330	Mounting plate
36	1440764	Insulative spacer
37	1982352	Radiator
38	2080215	Electric box
39	1982666	Connecting board
40	1993154	Terminal panel
41	1982350	Mounting plate
42	2078758	Power terminal panel
43	1983163	Display board
44	1982477	Temperature sensor
45	1982478	Temperature sensor

OUTDOOR UNIT
WHP24M3A21S

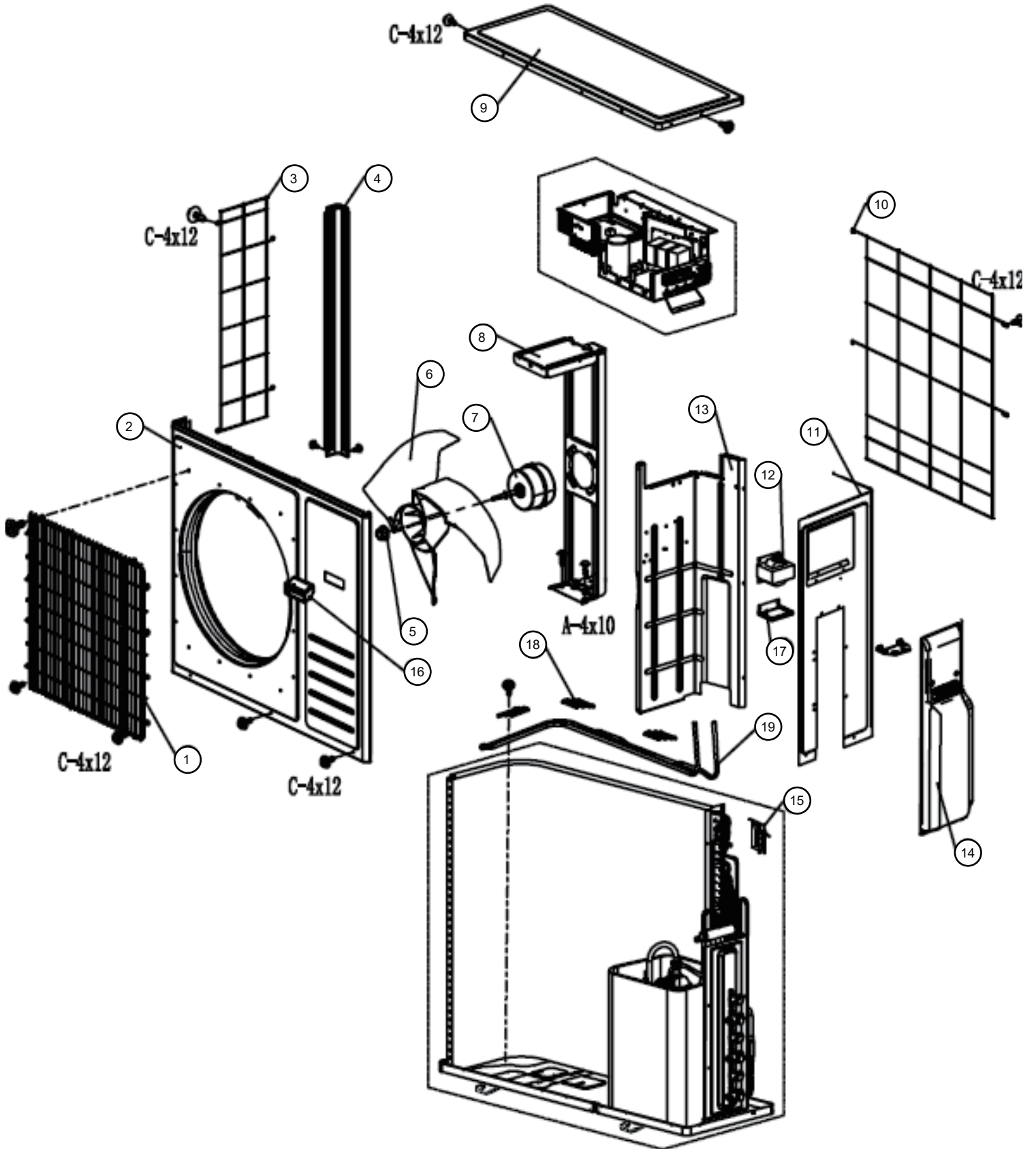

OUTDOOR UNIT
WHP24M3A21S

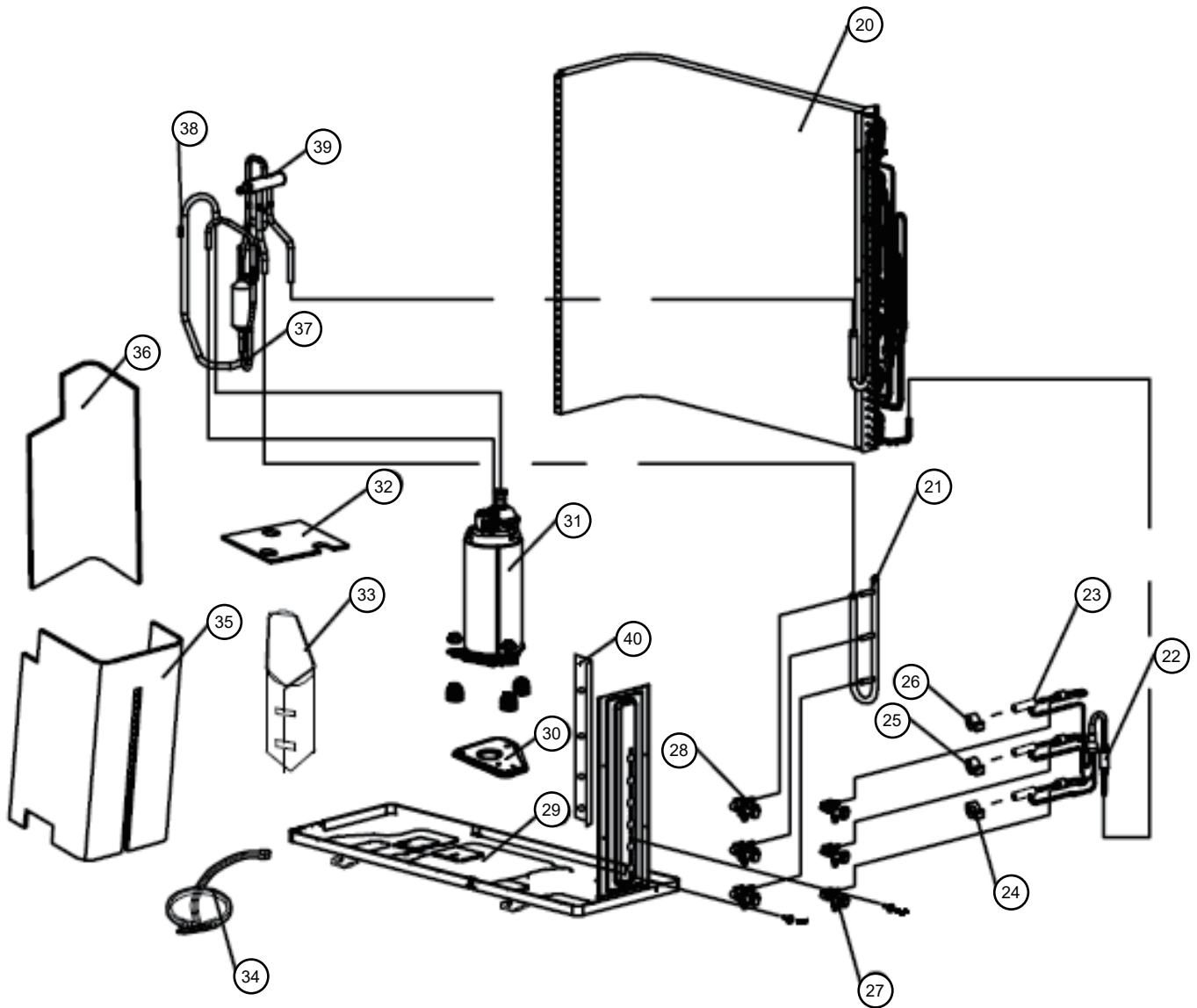

OUTDOOR UNIT
WHP24M3A21S

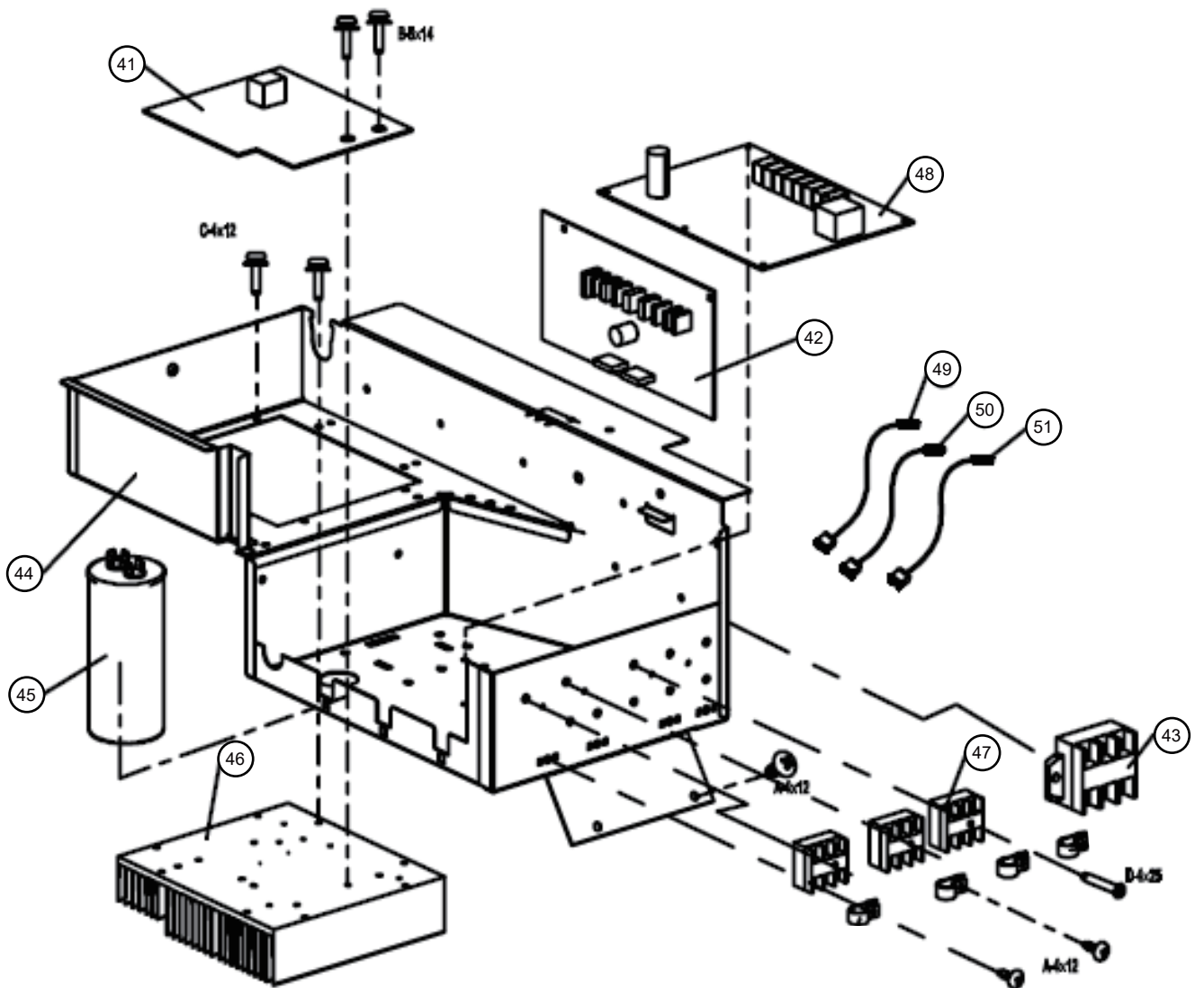

OUTDOOR UNIT
WHP24M3A21S

No.	Part number	Description
1	2118361	Fan guard
2	2118319	Front panel
3	1469450	Left guard filter
4	1382782	Mounting plate
5	1231108	Nut
6	1899961	Propeller fan
7	1421124	Fan motor
8	2031731	Motor bracket
9	1908421	Upper cover
10	1469447	Back guard filter
11	1301634	Side panel parts
12	1302261	Choke coil
13	1839170	Separate plate assy
14	2015920	Valve cover
15	1546721	Senser mount plate
16	1202703	Handle
17	2012524	Baffle
18	1993788	Plate cover
19	1993517	Tube electric heater
20	1953349	Condenser assy
21	1357788	Pipe assy
22	1855202	Outlet tube assy
23	1384279	EEV assy
24	1979761	EEV coil
25	1980925	EEV coil
26	1980932	EEV coil

No.	Part number	Description
27	1521397	1/4 stop valve assy
28	1521423	3/8 stop valve assy
29	1985758	Base parts
30	2008554	Mounting plate
31	1993782	Compressor
32	2025800	Soundproof cotton
33	2025809	Soundproof cotton
34	1391303	-
35	2025801	Soundproof cotton
36	2025803	Soundproof cotton
37	2014921	Suction tube assy
38	2014920	Discharge tube assy
39	2014923	Valve 4 way TA
40	2009519	Mounting plate
41	1993628	Driver board
42	1993571	Inverter control PCB
43	1993625	Filter board
44	2013786	Elec joint box assy
45	1469172	Aluminum capcitor
46	1933518	Radiator
47	1993154	Terminal panel
48	1993161	Power terminal panel
49	1982477	Temperature sensor
50	1982478	Temperature sensor
51	1982482	Temperature sensor
	1996374	4-way valve coil

OUTDOOR UNIT
WHP36M4A21S

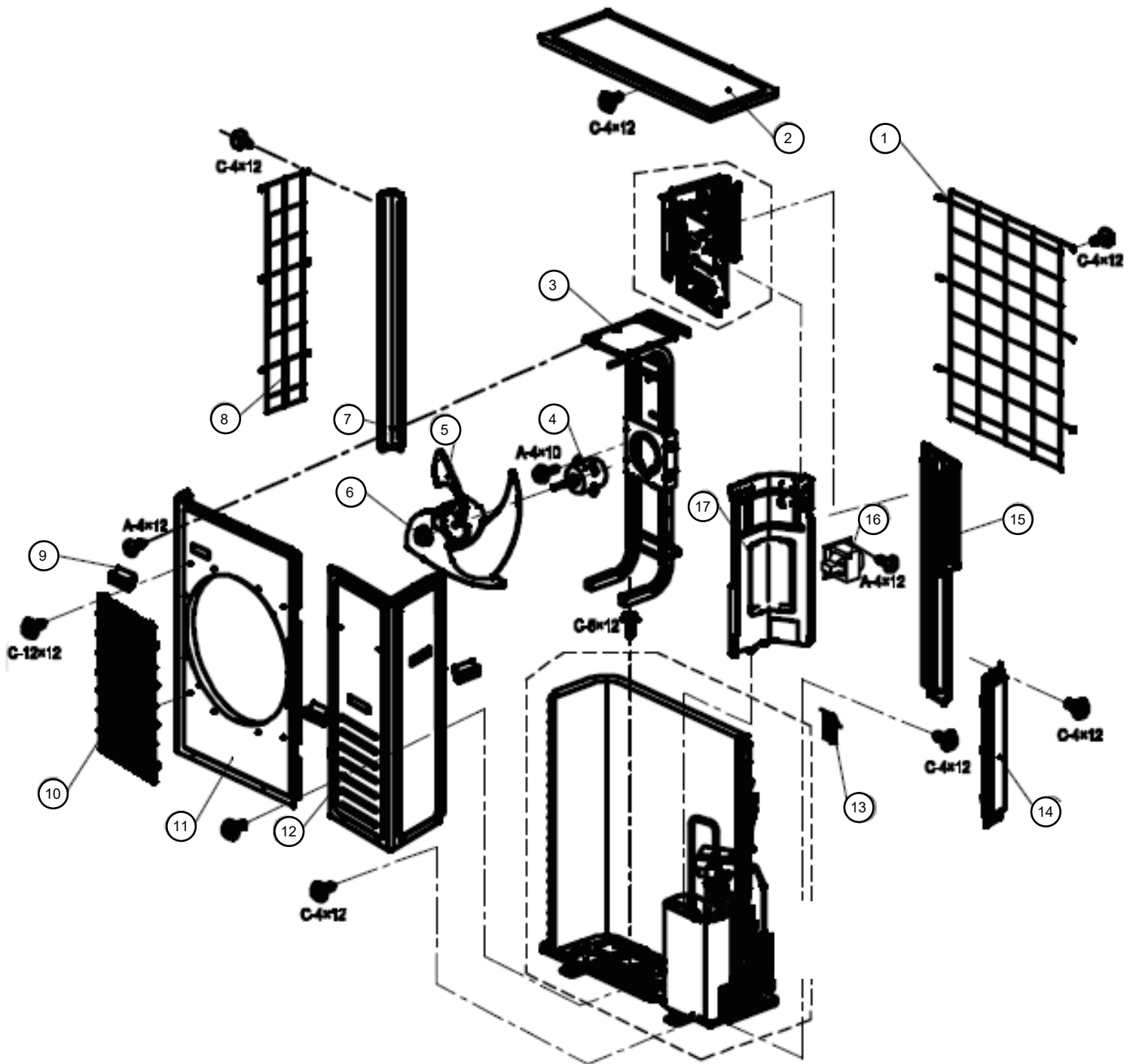

OUTDOOR UNIT
WHP36M4A21S

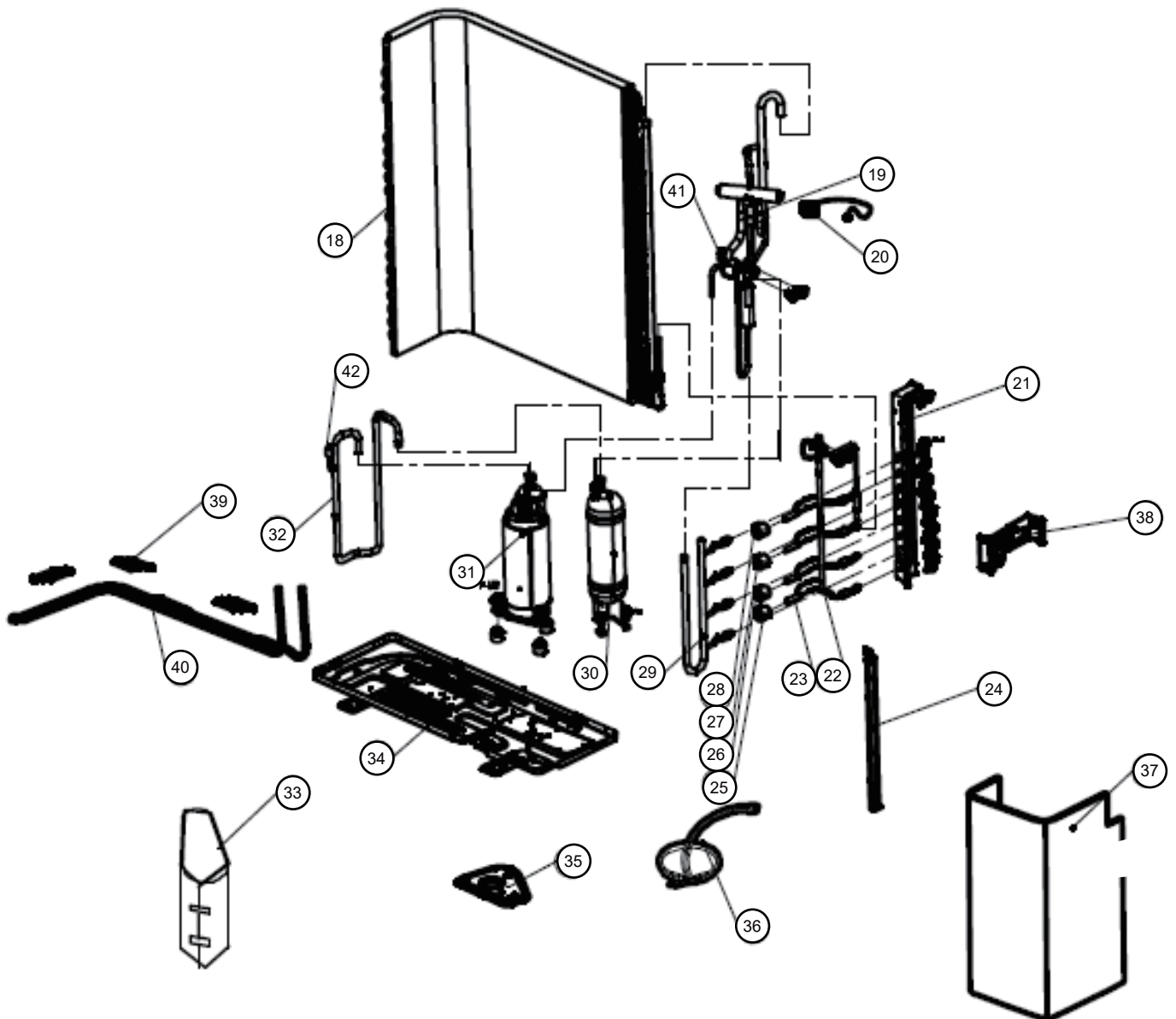

OUTDOOR UNIT
WHP36M4A21S

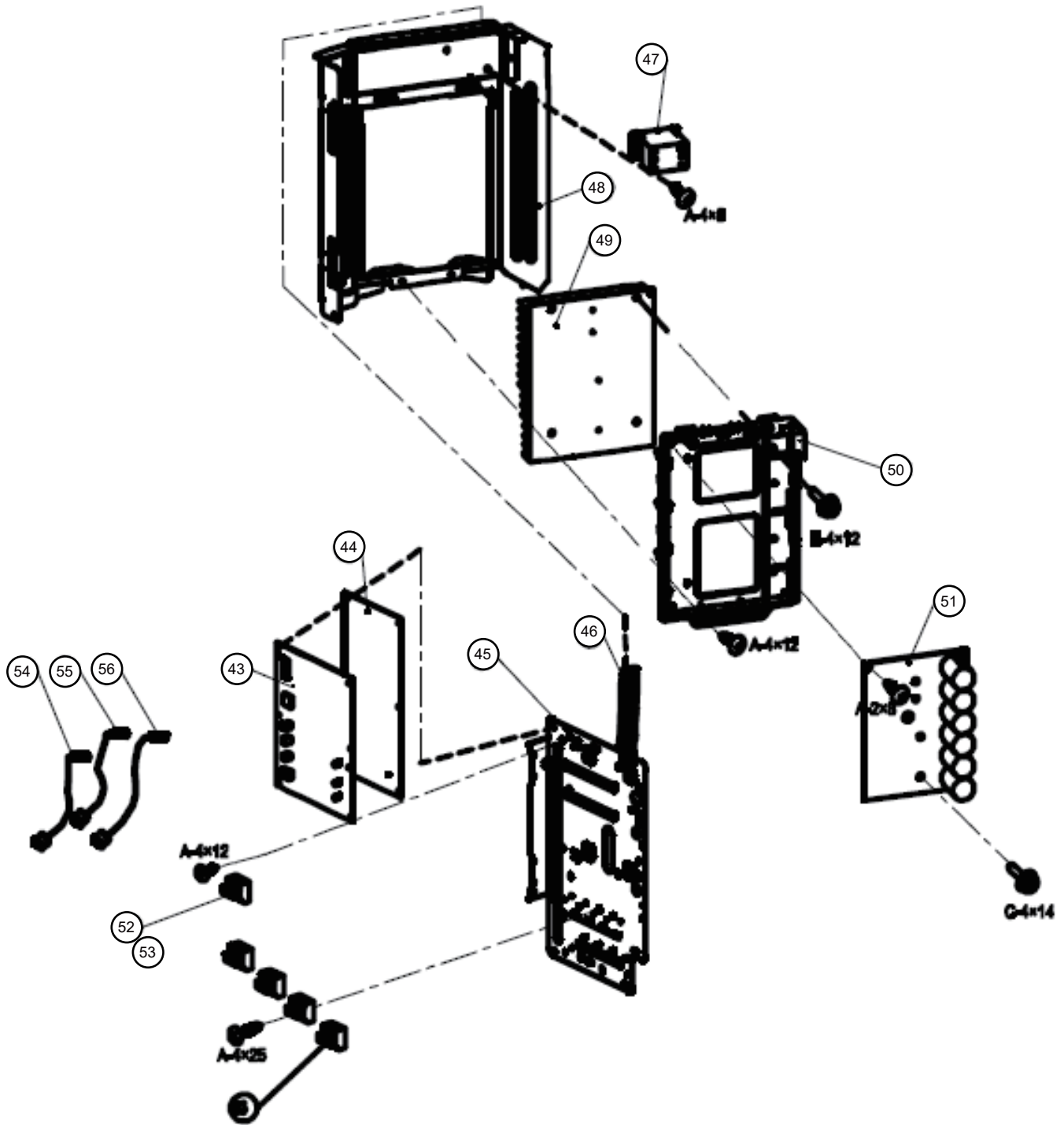

OUTDOOR UNIT
WHP36M4A21S

No.	Part number	Description
1	1556829	Guard filter
2	1400459	Top panel
3	1889202	Motor bracket
4	1498534	DC motor
5	1947347	Propeller fan blade
6	1398867	Welding hex nuts
7	1424902	Mounting plate
8	1482994	Protective net left
9	1202703	Handle
10	2118361	Fan guard
11	2118320	Intake grille
12	2001452	Service plate
13	1546721	Senser mount plate
14	2001457	Valve cover
15	2014366	Side board
16	1400760	Choke coil
17	2023804	Separate plate
18	1566024	Condenser
19	1999729	Valve 4 way TA
20	1996374	4-way valve coil
21	2023363	Supporting component
22	1998739	EEV assembly
23	1816562	EEV
24	2001454	Mounting plate
25	1979761	EEV coil
26	1848625	EEV coil
27	2000948	EEV coil
28	2000949	EEV coil

No.	Part number	Description
29	1998740	Bypass tube assembly
30	1393892	Gas-liquid separator
31	2000141	Compressor
32	1999752	S tube assembly
33	2025799	Soundproof cotton
34	2001557	Base assembly
35	2008554	Mounting plate
36	2007849	Crankcase heater
37	2025749	Soundproof cotton
38	2014382	Supporting component
39	1993788	Plate cover
40	2000085	Tube electric heater
41	1992630	Pressure switch
42	2008271	Pressure switch
43	2001991	Inverter control PCB
44	1998620	Filter board
45	2022499	Mounting plate assy
46	1464299	Connecting plate
47	1343638	AC contactor
48	1464281	Mounting plate
49	1916769	Radiator
50	1519508	Mounting plate
51	2002099	Driver board
52	1993161	Wire terminal board
53	1993154	Wire terminal board
54	1982480	Temperature sensor
55	1995950	Temperature sensor
56	1995952	Temperature sensor

OUTDOOR UNIT
WHP42M5A21S

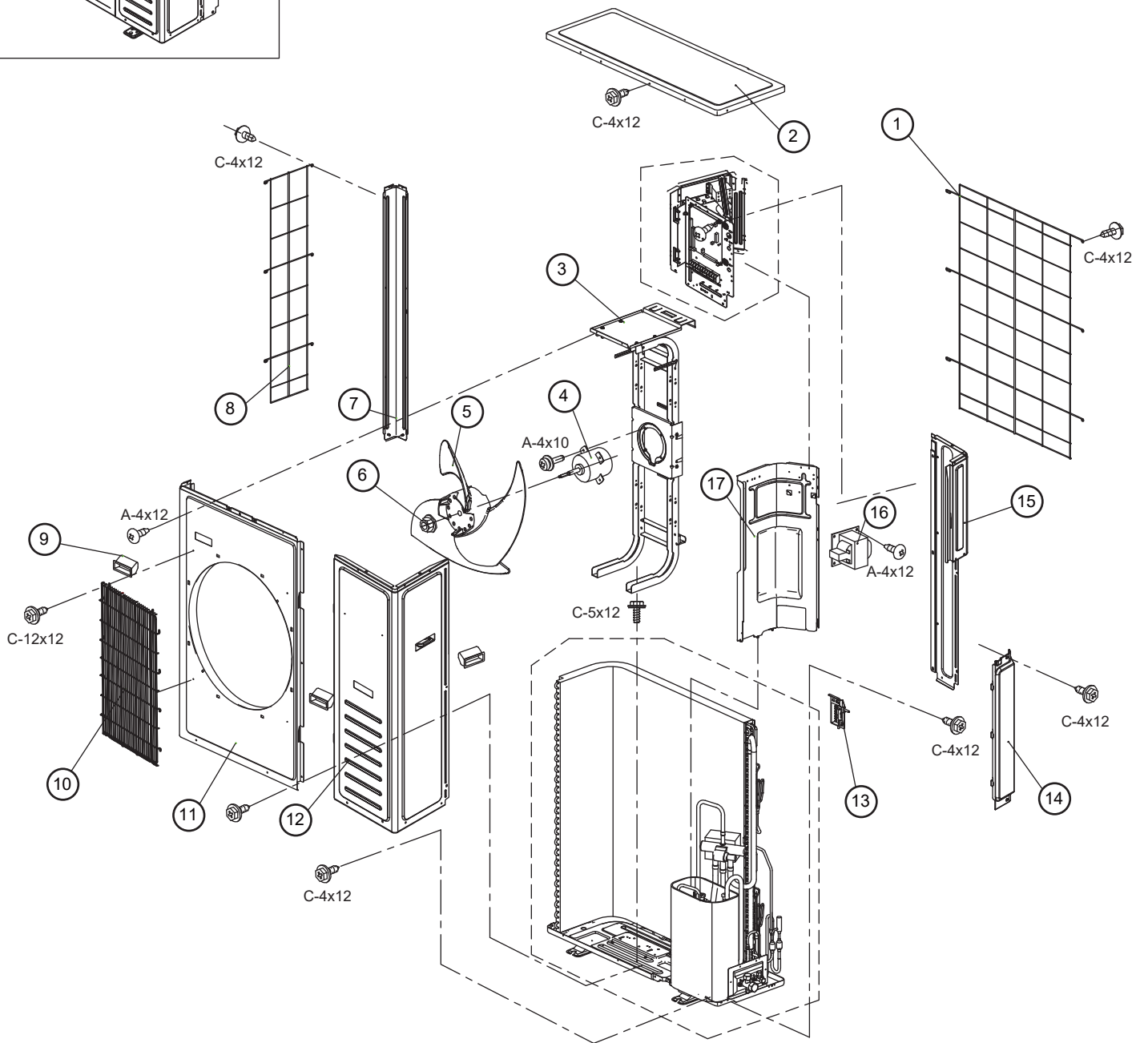
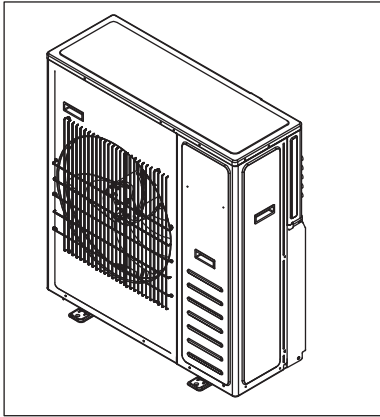

OUTDOOR UNIT
WHP42M5A21S

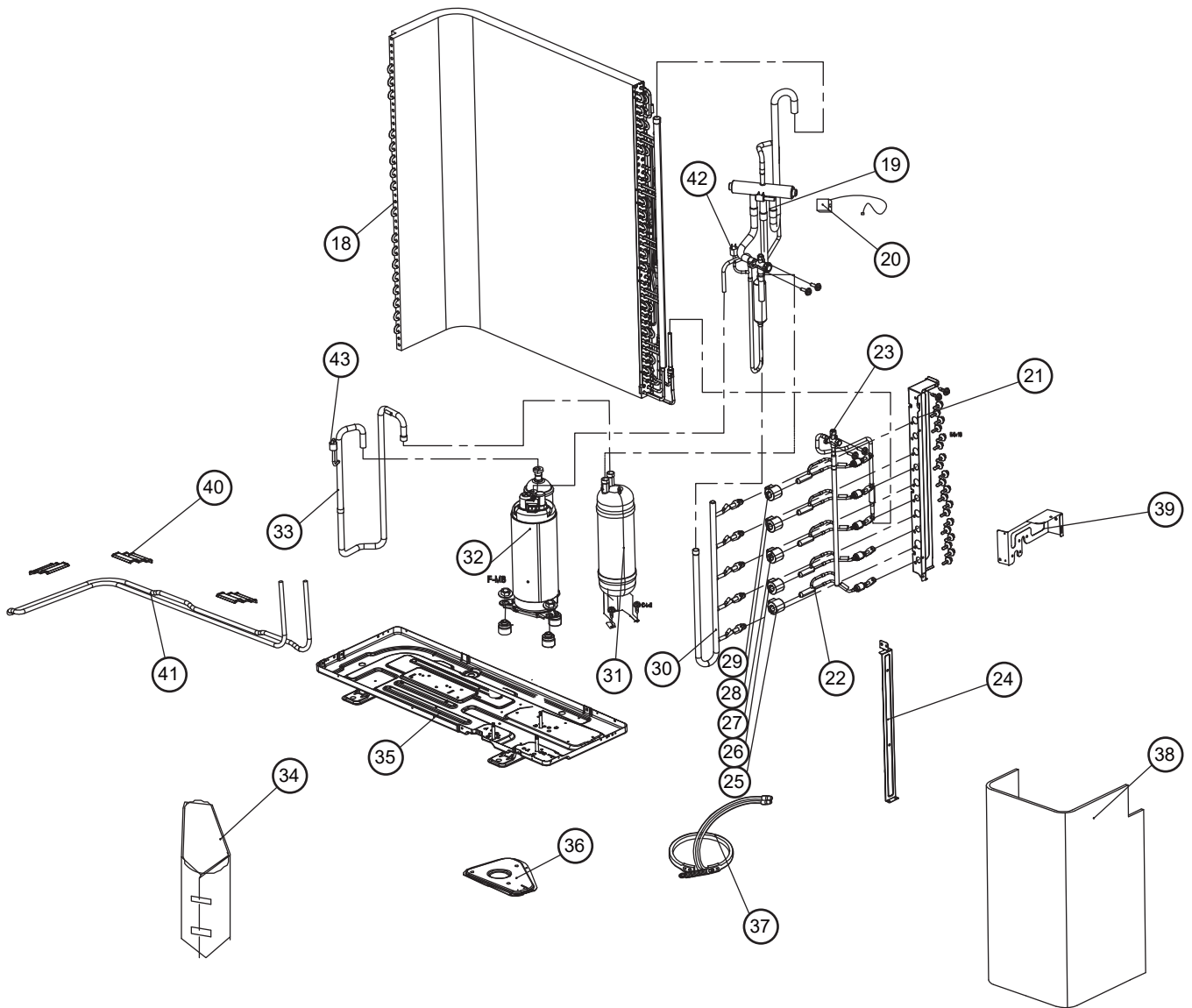
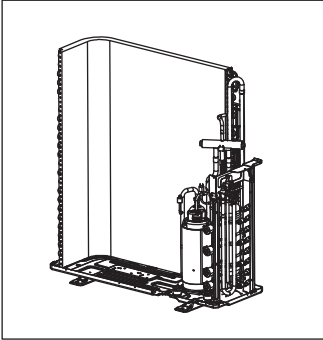

OUTDOOR UNIT
WHP42M5A21S

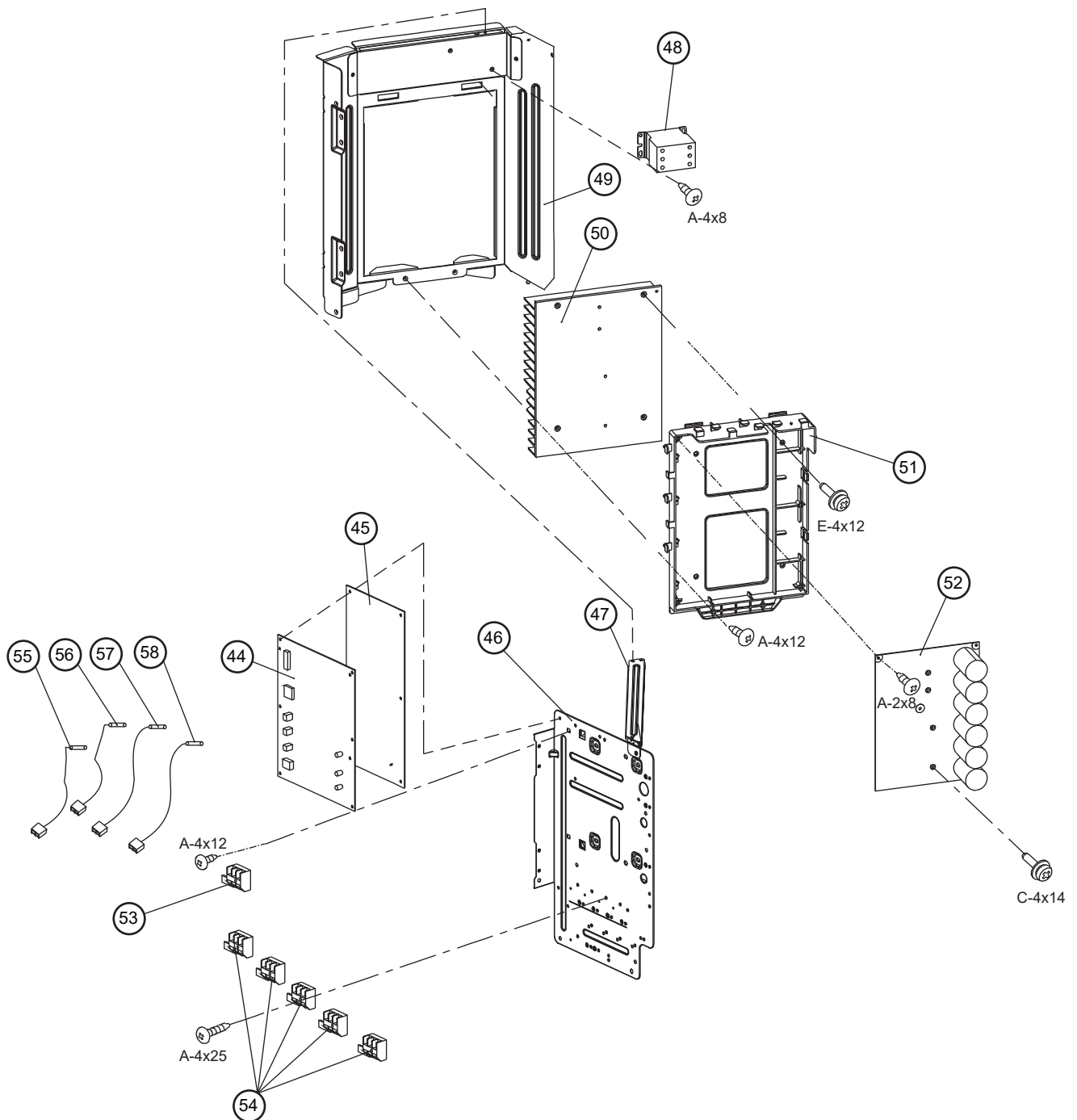
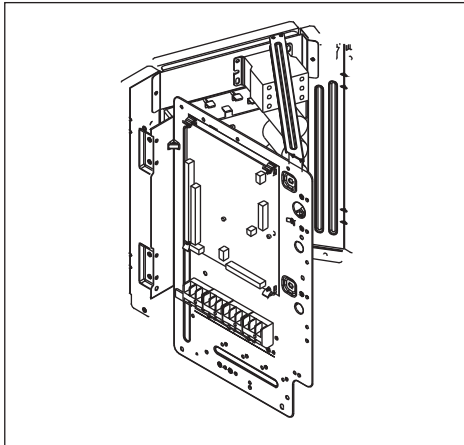

OUTDOOR UNIT
WHP42M5A21S

No.	Part number	Description
1	1556829	Guard filter
2	1400459	Top panel
3	1889202	Motor bracket
4	1498534	DC motor
5	1947347	Propeller fan blade
6	1398867	Welding hex nuts
7	1424902	Mounting plate
8	1482994	Protective net left
9	1202703	Handle
10	2118361	Fan guard
11	2118320	Intake grille
12	2001452	Service plate
13	1546721	Senser mount plate
14	2001457	Valve cover
15	2014366	Side board
16	1400760	Choke coil
17	2023804	Separate plate
18	1566024	Condenser
19	2083539	4-way valve
20	1996374	4-way valve coil
21	2014242	Supporting component
22	2084842	EEV assembly
23	2000090	Valve assembly
24	2001454	Mounting plate
25	1979761	EEV coil
26	1848625	EEV coil
27	2000948	EEV coil
28	2000949	EEV coil
29	2026015	EEV coil

No.	Part number	Description
30	2025349	Bypass tube assembly
31	2083541	Gas-liquid separator
32	2000141	Compressor
33	2084795	S tube assembly
34	2025799	Soundproof cotton
35	2001557	Base assembly
36	2008554	Mounting plate
37	2007849	Crankcase heater
38	2025749	Soundproof cotton
39	2014382	Supporting component
40	1993788	Plate cover
41	2000085	Tube electric heater
42	1992630	Pressure switch
43	2008271	Pressure switch
44	2087391	Inverter control PCB
45	1998620	Filter board
46	2022499	Mounting plate assy
47	1464299	Connecting plate
48	1343638	AC contactor
49	1464281	Mounting plate
50	1916769	Radiator
51	1519508	Mounting plate
52	2002099	Driver board
53	1993161	Wire terminal board
54	1993154	Wire terminal board
55	1982480	Temperature sensor
56	1995950	Temperature sensor
57	1995952	Temperature sensor
58	1982482	Temperature sensor

Accessories

Wall mounted type

■ Models: WHP07WMA21S, WHP09WMA21S, WHP12WMA21S, WHP18WMA21S, and WHP24WMA21S

Part name	Q'ty	Part name	Q'ty
Remote controller instructions	1	Drain joint rubber seal	1
Use and installation instructions	1	Flare nuts	4
Remote controller	1	Bag of wall anchors and screws	1
Remote controller holder	1	Screw for installations	5
AAA battery	2	Screw cover	07-12 model: 1 18/24 model: 3
Foam insulation	07-18 model: 1 24 model: 2	Warranty Card	1
Drain joint	1		

Cassette type

■ Models: WHU09CTA21S, WHU12CTA21S, WHU18CTA21S, and WHU24CTA21S

Part name	Q'ty	Part name	Q'ty
Use and installation instructions	1	Built-in type drain pump	1
Dry battery	2	Wireless remote controller	1
Indoor installation accessory kit (For 18, 24 models)	1	Wireless remote controller operation manual	1
Union nut (Gas)	1	Wireless remote controller holder	1
Union nut (Liquid)	1	Warranty card	1

Duct type

■ Models: WHU09DHA21S, WHU12DHA21S, WHU18DHA21S, and WHU24DHA21S

Part name	Q'ty	Part name	Q'ty
Use and installation instructions	1	Built-in type drain pump	1
Indoor installation accessory kit (clammer, plain washers) (For 18, 24 models)	1	Indoor installation accessory kit (sponge, fixing clip, water pipe parts)	1
Warranty card	1	Wired remote controller operation manual	1
Union nut (Gas)	1	Wired remote controller	1
Union nut (Liquid)	1		

Outdoor unit

■ Models: WHP18M2A21S, WHP24M3A21S, WHP36M4A21S, and WHP42M5A21S

Part name	Q'ty	Part name	Q'ty
Use and installation instructions	1	Valve adapter-2 3/8 in to 5/8 in (9.52 mm to 15.88 mm) (For 36 and 42 model)	1
Drain joint	1	Valve adapter-3 1/4 in to 3/8 in (6.35 mm to 9.52 mm) (For 36 and 42 model)	1
Valve adapter-1 3/8 in to 1/2 in (9.52 mm to 12.70 mm) (For 24, 36, and 42 model)	1		

